



**TOWNSHIP OF MELANCTHON
HYBRID COUNCIL MEETING
THURSDAY, JUNE 4, 2026 - 5:00 P.M.**

Council meetings are recorded and will be available on the Township website under Quick Links – Council Agendas and Minutes within 5 business days of the Council meeting.

Join Zoom Meeting

<https://us02web.zoom.us/j/82206752715?pwd=FPLWNgcNt70q9Pju7sHxXZZR28ZUaB.1>

Meeting ID: 822 0675 2715

Passcode: 576005

One tap mobile

+16475580588,,82206752715#,,,,*576005# Canada

+17789072071,,82206752715#,,,,*576005# Canada

AGENDA

1. Call to Order

2. Land Acknowledgement Statement

We will begin the meeting by sharing the Land Acknowledgement Statement:

We would like to begin by acknowledging that Melancthon Township recognizes the ancestral lands and treaty territories of the Tionontati (Petun/Wyandot(te)), Haudenosaunee (Six Nations), and Anishinaabe Peoples. The Township of Melancthon resides within the lands named under the Haldimand Deed of 1784 and the Lake Simcoe-Nottawasaga Treaty (Treaty 18).

These territories upon which we live and learn, are steeped in rich Indigenous history and traditions. It is with this statement that we declare to honour and respect the past and present connection of Indigenous peoples with this land, its waterways and resources.

3. Announcements

4. Additions/Deletions/Approval of Agenda

5. Declaration of Pecuniary Interest and the General Nature Thereof

6. Approval of Draft Minutes – May 21, 2026

7. Business Arising from Minutes

1. 164 Shelburne Air Cadets Funding Request – Update (Councillor Plowright)

- 8. Point of Privilege or Personal Privilege**
- 9. Public Question Period** (Please visit our website under Agendas and Minutes for information on Public Question Period)
- 10. Public Works**
 1. Accounts
 2. Other
- 11. Planning**
 1. Other
- 12. Strategic Plan**
- 13. Climate Change Initiatives**
- 14. Dufferin OPP Detachment Board – Melancthon, Mono, Mulmur**
- 15. County Council Update**
 1. Council Highlights – May 14, 2026
- 16. Committee/Board Reports & Recommendations**
- 17. Correspondence**

Board, Committee & Working Group Minutes

1. Mulmur Melancthon Fire Board Minutes – May 18, 2026
2. Melancthon Parks and Recreation Board – April 27, 2026
3. Shelburne Public Library Board April 28, 2026

Items for Information Purposes

1. Town of Shelburne Resolution – Opposition to Bill 97
2. RJ Burnside and Associates – Drainage Superintendent Services – January 1 – March 26, 2026
3. Letter from Sylvia Jones, MPP regarding Police Record Checks
4. Letter from Ministry of the Attorney General regarding Follow-up to “Tailgate Event” Permits
5. Mulmur Melancthon Fire Department 2025 Annual Report
6. GRCA – Consolidation of Cas – Transition Committees
7. Hon. Robert J. Flack, Minister of Municipal Affairs Letter to the Town of Caledon regarding the Town’s Official Plan Amendment 1

Items for Council Action

1. Niagara Escarpment Commission Request for Comments – APP-2026-00101 – 518693 County Road 124
2. Resignation of Sue Shier from the Horning’s Mills Community Hall Board

18. General Business

1. Accounts
2. New/Other Business/Additions
3. Unfinished Business
 1. Councillor Ralph Moore Resignation from Council
 1. Motion to declare seat vacant
 2. Legal Opinion from Stephen Christie regarding filling the Vacancy – Discussion & Direction
 2. Comments from Bret Lemieux, Bluewater Geoscience Consultants Inc. regarding his review of the Shelburne Strada, Annual Compliance Report

3. TAMPO Membership (Councillor Plowright)
4. Amendment to the Township Salvage Yard By-law (Mayor White)
5. Melancthon Township Bu
4. Reports/Updates from Members of Council & Administrative Staff

19. Delegations

1. 6:30 p.m. - David Germain, Thomson Rogers and David Donnelly, Donnelly Law, Township Solicitors regarding the Strada Aggregates Applications (**this Delegation will be in Closed Session under Section 239(2)(f) of the *Municipal Act, 2001* – Advice that is subject to Solicitor/Client Privilege**)

20. Closed Session

1. Items for Discussion:
 1. Delegation #1 – Section 239(2)(f) – Advice that is subject to Solicitor-Client Privilege
 2. Correspondence Update from Ted Oldfield, Township Solicitor regarding a By-law Complaint Matter – Section 239(2)(f) – Advice that is subject to Solicitor-Client Privilege
2. Approval of Draft Minutes – May 21, 2026
3. Business Arising from Minutes
4. Rise With or Without Report from Closed Session

21. Notice of Motion

22. Confirmation By-law

23. Adjournment and Date of Next Meeting – Thursday, June 18, 2026 – 5:00 p.m.



Council Highlights

County of Dufferin
55 Zina Street, Orangeville, Ontario

For Immediate Release: May 20, 2026

Dufferin County Council met on Thursday, May 14, 2026, for a Council meeting. For the full Council meeting agenda and minutes, please see the County's [Meeting Agendas and Minutes page](#).

Here are the highlights of the May 14 meeting:

- [Dufferin County Council proclaimed May Lupus Awareness Month](#)
- [Dufferin County Council proclaimed May Multiple Sclerosis Awareness Month](#)
- [Dufferin County Council proclaimed May 17 to 23 Paramedic Services Week](#)
- [Dufferin County Paramedic Services' Chief Paramedic reported on rural response times in Dufferin County](#)
- [County Council received report on Council Remuneration Review for the 2026 to 2030 term and set rates for Councillors and the Deputy Warden](#)
- [County Council approves implementation of an additional transit stop in the Primrose area on Grey Transit Route 2 as a six-month pilot commencing in July 2026](#)
- [County Council approves implementation of a voluntary Green Development Program in partnership with Grey and Wellington Counties](#)
- [County Council nominated Councillor Chris Gerrits for the position Director, County Caucus, on the AMO Board of Directors for the 2026 to 2028 term](#)

Dufferin County Council proclaimed May Lupus Awareness Month

Dufferin County Council proclaimed May as Lupus Awareness Month in Dufferin. Jordyn Lavecchia-Smith, Lupus Ontario Board Member, attended the meeting to accept the proclamation.

Lupus Awareness Month is dedicated to educating the public about this complex autoimmune disease, advocating for earlier diagnoses, funding research, and supporting the millions of people living with its unpredictable symptoms

Dufferin County Council proclaimed May Multiple Sclerosis Awareness Month

Dufferin County Council proclaimed May as Multiple Sclerosis Awareness Month in Dufferin. James Jackson, Dufferin-Caledon MS Ambassador, and Jeff Mamer, Senior Director Community, Ontario, MS Canada, attended the meeting to accept the proclamation.

MS Awareness Month is dedicated to funding research, sharing lived experiences, and supporting the millions of people affected by MS

Dufferin County Council proclaimed May 17 to 23 Paramedic Services Week

Dufferin County Council proclaimed May 17 to 23 as Paramedic Services Week in Dufferin.

The theme of Paramedic Services Week for 2026 is “Improving Outcomes, Together”. Improving Outcomes, Together extends beyond medicine. It’s a collective responsibility that involves investing in the people behind the care with fair pay, safe staffing levels, mental health resources, leadership that listens and acts, and opportunities for professional growth.

Dufferin County Paramedic Services’ Chief Paramedic reported on rural response times in Dufferin County

At the April 23, 2026 Council meeting, the Chief of Paramedic Services was asked to report back on response times, with a specific focus on disparities affecting rural municipalities and areas.

Dufferin County Paramedic Service provides land ambulance service to approximately 66,000 residents and visitors across Dufferin County. Dufferin County spans more than 1,400 sq. km and includes eight distinct municipalities. Most of the population is concentrated in the more urban area surrounding the Town of Orangeville.

Dufferin County Paramedic Service currently operates from three stations: Orangeville, Shelburne, and Grand Valley. In 2025, total call volume was 9,180, with 6,024 patients requiring transport to hospital. The average response time for all calls in Dufferin County was 08:45, and the average response time for high-acuity calls was 07:02.

County Council received report on Council Remuneration Review for the 2026 to 2030 term and set rates for Councillors and the Deputy Warden

Under the County’s By-Law 2022-30, the County must conduct a formal review of Council remuneration once per term, with any changes to take effect at the start of the 2026 to 2030 Council term. County Council received a report on the Council Remuneration Review for the 2026 to 2030 term and increased rates for Councillors by \$1,896.48. Council also set a rate of an additional \$1,5000 above the Councillor compensation for the position of Deputy Warden.

County Council approves implementation of an additional transit stop in the Primrose area on Grey Transit Route 2 as a six-month pilot commencing in July 2026

Grey Transit Route 2 continues to provide a critical connection between Dundalk and Orangeville, supporting access to employment, health and human services, and regional transit, with strong ridership of 7,142 trips recorded in 2025.

Demand for service has increased in recent years, resulting in expanded service levels, including the addition of a second vehicle and eight daily trips, ensuring continued capacity for Dufferin County residents.

County staff have received renewed requests to reinstate a transit stop in Primrose (near the Shelburne Motel) to address growing client need and improve equitable access to essential services for individuals experiencing transportation barriers.

County Council approved a six-month pilot beginning July 2026 to assess ridership, operational impacts, and safety considerations, with an estimated cost of \$2,490 that can be accommodated within the 2026 budget.

County Council approves implementation of a voluntary Green Development Program in partnership with Grey and Wellington Counties

Dufferin County Council approved the implementation of a voluntary Green Development Program in partnership with Grey and Wellington Counties, with an anticipated launch in Summer 2026.

The Program will support reduced long-term housing costs, improved resilience to climate risks, and economic development in the green building sector. It establishes a consistent regional framework to support higher-performing residential development while reducing duplication for municipalities and the development industry.

The Green Development Program has been designed as a voluntary, points-based system with three core components: Metrics, Recognition and Capacity Building.

County Council nominated Councillor Chris Gerrits for the position Director, County Caucus, on the AMO Board of Directors for the 2026 to 2028 term

About Dufferin County Council

Dufferin County Council consists of 15 members representing each of the eight municipalities in Dufferin. Council meeting processes are set out in the County's Procedural By-Law.

Dufferin County Council and Committee meetings can be watched live on the [County's website](#).

-30-

MEDIA CONTACT:

Megan Ball, Manager of Communications
mball@dufferincounty.ca



MULMUR-MELANCTHON FIRE BOARD MINUTES

March 18, 2026

Present: Bill Neilson, Chair – Melancthon Township
Kim Lyon, Vice Chair – Mulmur Township
Earl Hawkins – Mulmur Township
Ralph Moore – Melancthon Township
Mathew Waterfield – Fire Chief
Jeff Merkley – Acting Deputy Fire Chief
Roseann Knechtel – Secretary

1. Call to Order

The Chair called the meeting to order at 5:38 p.m.

2. Land Acknowledgement

We begin this meeting by acknowledging that we are meeting upon the traditional Indigenous lands of the Tionontati (Petun) and Treaty 18 territory of the Anishinaabe peoples. We recognize and deeply appreciate their historic connection to this place and we also recognize the contributions Indigenous peoples have made, both in shaping and strengthening our community, province and country as a whole.

3. Approval of the Agenda

Moved by Moore Seconded by Hawkins

That the agenda be approved.

Carried.

4. Minutes of the Previous Meeting

Moved by Hawkins Seconded by Moore

That the minutes of January 21, 2026 be approved.

Carried.

5. Declaration of Pecuniary Interest - None

6. Administration

6.1 Argo UTV

Members discussed the replacement of the 2000 Argo. A committee of 3 firefighters explored and obtained quotes for various options. Members reviewed the capital budget and discussed the sale of the current Argo to help offset the costs.

Moved by Hawkins Seconded by Moore

That the Mulmur–Melancthon Fire Board approve the purchase of the 2026 Argo Aurora 950 with a removable winter track system and authorize staff to place the order.

Carried.

6.2 Fire Boards General Discussion - None

6.3 General Fire Chief Update

Chief Waterfield updated Members on Department activities, noting:

- A total of 13 calls to date in 2026 with the majority being MVC's.
- Provincial Fire Service Grant materials have been delivered. Masks need to be fitted and tested. This will be completed internally.
- Generator repair ongoing

7. Information Items

7.1 Accounts

7.2 2026 Budget to Actual

Moved by Lyon Seconded by Moore

That the Mulmur-Melancthon Fire Board receive the information items as presented.

Carried.

8. Items for Future Meetings

8.1 Fire Chief Performance Review Policy

8.2 Deputy Chief/Captain Performance Review Policy

8.3 2025 Annual Report

10. Adjournment

Moved by Hawkins Seconded by Lyon

That we do now adjourn at 6:07 p.m. to meet again on May 13, 2026 at 5:30 pm, in person at the Mulmur-Melancthon Fire Hall, or at the call of the Chair.

Carried.

Chair

Secretary

CORPORATION OF THE TOWNSHIP OF MELANCTHON

The Township of Melancthon Parks and Recreation Board held a meeting on April 27, 2026, at 7:00 p.m. The following members were present: Chair Bill Neilson, Vice-Chair David Thwaites, Members Jessica Plowright, Lynn Hodgson, Doug Read and Darren White, also present was Becky Cunnington, Parks and Recreation Board Secretary. Absent was member Ruth Plowright. The meeting was called to order at 6:55 p.m.

Land Acknowledgement

Chair Neilson shared the Land Acknowledgement Statement.

Additions/Deletions/Approval of Amended Agenda

Additions

None

Deletions

None

Approval of Agenda

Moved by J. Plowright, Seconded by Thwaites that the agenda be approved as circulated. Carried.

Approval of Minutes

Moved by Hodgson, Seconded by Read that the minutes of the Parks and Recreation Board Meeting held on April 27, 2026, be approved as circulated. Carried.

Business Arising from Minutes

None

Declaration of Pecuniary Interest or Conflict of Interest

No declaration declared at this time.

General Business

1) New

1. Picnic Tables

Member White reviewed the picnic table frame options that had previously been circulated to Board members by email and suggested purchasing six frames, along with the required lumber for the tabletops, to be constructed and installed at the Corbetton and Horning's Mills Parks.

Township Staff advised that, should the Board wish to proceed with the project this year, funding would need to come from the Parks and Recreation Board bank account, as the item was not included in the approved 2026 budget.

Following discussion, Vice-Chair Thwaites introduced the following motion:

Motion:

Moved by Vice-Chair Thwaites, seconded by Member J. Plowright, that the Parks and Recreation Board approve the purchase of materials required to construct six picnic tables, with funding to be provided from the Parks and Recreation Board bank account.

Carried.

1) Unfinished Business

1. Horning's Mills Park

i. Blue Jay Grant

This item was not discussed, as consideration of the future use of the park is required before proceeding.

ii. Future Use of the Park

iii. A lengthy discussion took place regarding various options for the future use of the park. It was determined that an onsite visit would be beneficial in helping establish a vision for the park moving forward. The Board agreed that the next Parks & Recreation meeting would be held at Horning's Mills Park.

iv. Rentals

No new rentals have been confirmed.

v. Sign

Deffered until the next meeting.

2. Corbetton Park

i. Slide

Township Staff advised that the quote received for the installation of the slide did not include the preparation of the site. Arrangements are being made to have the company representative meet onsite with Public Works Superintendent and a member of the Board to discuss the placement of the slide and site requirements to determine if the Township can do the work or if it needs to be contracted out. Member White

volunteered to do the onsite meeting. Township Staff will coordinate the meeting and provide him with the details.

ii. Shade Covers/Sails

Members White, Read, and J. Plowright agreed to meet at the park to review and discuss potential locations for the installation of shade covers.

3. Melancthon Day

i. Ball Tournament

Member R. Plowright was absent, so no update was given.

ii. We The Bounce

Township Staff advised that the deposit had been paid and the booking was confirmed.

iii. Mulmur Melancthon Fire Department

Chair Neilson shared that the Mulmur Melancthon Fire Department has confirmed that they will be running the BBQ again this year, beginning at 5:00p.m.

4. Touch a Truck Event

Member Read reported that the owner of the "Tow Mater" look-alike truck is available to attend on August 8, 2026. He will also follow up regarding any fees associated with having the vehicle attend. Chair Neilson will contact Blitzful Treats to inquire about attending the event to provide ice cream and treats. He will also reach out to the Shelburne Fire Department to invite them to participate.

5. Rail Trail Collaboration with the County

Township Staff reported that discussions had taken place with the County and advised that Tourism and Economic Development projects are currently on hold. However, the County indicated they would be willing to assist in promoting and advertising any events shared with them.

6. Winter Use of Parks

The Board discussed the report prepared by Township Staff and agreed to make a recommendation to Council for a pilot project to maintain winter maintenance of the Corbetton Park parking lot during the 2026–2027 winter season.

7. Survey Questions

Deferred. A suggestion box is being introduced to gather feedback and information.

2) Brainstorming

None

Recommendation to Council

As a result of this discussion, the Board recommends that Council approve a pilot project for the 2026/2027 winter season to provide winter maintenance of the parking lot at the Corbetton Park.

Public Question Period

None.

Confirmation Motion

Moved by Thwaites, Seconded by Hodgson that all actions of the Members and Officers of the Parks and Recreation Board with respect to every matter addressed and/or adopted by the Board on the above date are hereby adopted, ratified and confirmed; and each motion, resolution and other actions taken by the Board Members at the meeting held on the above date are hereby adopted, ratified and confirmed. Carried.

Adjournment

8:31 p.m. - Moved by Read, Seconded by J. Plowright that we adjourn this Parks and Recreation Board meeting to meet again on Monday May 25, 2026, at 7:00 p.m. or at the call of the Chair. Carried.

CHAIR

SECRETARY



Minutes of Shelburne Public Library Board – Amended*

Tuesday, April 28, 2026, 7 p.m.

KTH Room, 201 Owen Sound St, Shelburne, ON L9V 3L2

Members Present: G. Dunlop
T. Field
J. Hodder
Councillor L. Wegener (Shelburne)
Councillor P. Clark (Mulmur)

Members Absent: Councillor V. Paan (Amaranth)
Councillor M. Davie (Mono)
Councillor R. Plowright (Melanchthon)

Staff Present: S. McGrady, CEO
D. Lange, Treasurer

1. Call to Order

Chair G. Dunlop called the meeting to order at 7:01p.m.

2. Disclosures of (Direct or Indirect) Pecuniary Interest

None.

3. Land Acknowledgment

The Chair acknowledged that the Town of Shelburne resides within the traditional territory and ancestral lands of the Anishinaabe, including the Ojibway, Potawatomi, Chippewa and the People of the Three Fires Confederacy.

These traditional territories upon which we live, work, play and learn are steeped in rich Indigenous history and traditions. It is with this statement that we declare to honour and respect the past and present connection of Indigenous peoples with this land, its waterways and resources.

4. Approval of the Agenda

Motion 27-26

Moved by Councillor P. Clark

Seconded by T. Field

Be it resolved that we approve the agenda for the April 28, 2026, meeting as ammended.

Carried

5. Adoption of Minutes of Previous Meeting

Motion 28-26

Moved by T. Field

Seconded by Councillor P. Clark

Be it resolved that we approve the minutes of the Board meeting dated March 31, 2026.

Carried

6. Information Item – CEO Report

Motion 29-26

Moved by Councillor L. Wegener*

Seconded by J. Hodder*

Be it resolved that we receive the CEO Report for April 2026.

Carried

7. Staff Reports

7.1 Financial Report

Motion 30-26

Moved by J. Hodder

Seconded by T. Field

Be it resolved that the Financial Report of March 2026, be received and the Profit and Loss statement for March 2026 be approved.

Carried

7.2 Draft Financial Statements 2025

Motion 31-26

Moved by Councillor P. Clark

Seconded by Councillor L. Wegener

Be it resolved that the Draft Financial Statements for the year end December 31, 2025 be received.

Carried

7.3 Policy Review – Purchasing/Procurement, Safety, Security, and Emergencies in the Library, and Code of Conduct

Motion 32-26

Moved by J. Hodder

Seconded by Councillor P. Clark

Be it resolved that the Report – Policy Review – Purchasing/Procurement, Safety, Security, and Emergencies in the Library and Code of Conduct be received; and

That the Board approve the Purchasing/Procurement of Goods and Services policy (FN-03) as presented; and

That the Board approve the Safety, Security, and Emergencies in the Library policy (OP-02) as presented; and

That the Board approve the Code of Conduct policy (OP-03) as presented.

Carried

8. New Business

8.1 Move In Camera

Motion: 33-26

Moved by Councillor L. Wegener

Seconded by T. Field

Be it resolved that the Board move into a closed meeting at 8:08 p.m. pursuant to Section 16.1 (4) (b) of *The Public Libraries Act, R.S.O. 1990*, as amended; a matter in respect of which a board or committee of a board may hold a closed meeting under another Act; and

That as per section (239)(2) of *The Municipal Act*, the Shelburne Public Library Board enter closed session as per subsection (k): a position, plan, procedure, criteria or instruction to be applied to any negotiations carried on or to be carried on by or on behalf of the municipality or local board. 2001, c. 23, s. 239 (2); 2017, c.10, Sched. 1, s. 26

Carried

The Board entered closed session at 8:08 p.m.

8.1.2 Verbal Update from the CEO regarding quotes for eavestrough replacement.

Motion: 34-26

Moved by T. Field

Seconded by J. Hodder

That the Board rises from in-camera at 8:32 p.m. to resume regular business.

Carried

Motion: 35-26

Moved by: Councillor L. Wegener

Seconded by: J. Hodder

That the verbal update from the CEO be received as information; and

That the Board direct the CEO to work with Town staff to hire Jamieson & Son to replace the eavestroughs for \$15,106.40

Carried

9. Correspondence

10. Announcements

11. Date of Next Meeting

The next meeting of the Board is scheduled for Tuesday, May 26, 2026

12. Adjournment

Motion: 36-26

Moved by Councillor L. Wegener*

Seconded by T. Field

That we now adjourn at 8:39 p.m. to meet again on May 26, 2026, at 7 p.m. or at call of the Chair.

Carried



TOWN OF SHELburne

COUNCIL RESOLUTION

No. 2026-81

Date: April 27, 2026

Moved by: Councillor Guchardi

Seconded by: Councillor Benotto

WHEREAS the Council of the Town of Shelburne is committed to principles of transparency, accountability, and open access to information for all residents;

AND WHEREAS Freedom of Information (FOI) legislation is a vital tool that enables municipalities, journalists, and the public to access government records and ensure accountability in decision-making;

AND WHEREAS the Government of Ontario has introduced an omnibus budget bill (Bill 97) that includes significant changes to FOI laws, including provisions that may retroactively limit public access to certain government records;

AND WHEREAS these proposed changes may restrict the ability of the Town of Shelburne to access provincial information necessary for informed planning, infrastructure coordination, environmental stewardship, and advocacy on behalf of its residents;

AND WHEREAS the omnibus nature of the legislation combines multiple unrelated policy changes, including those affecting conservation authorities and land-use planning, which have direct implications for growing communities such as Shelburne;

AND WHEREAS the expedited legislative process, including limited or bypassed committee hearings, reduces opportunities for municipalities like Shelburne to provide meaningful input on policies that directly impact local governance;

AND WHEREAS such actions risk undermining public trust in government institutions and weaken the principles of open, transparent governance across all levels of government;

THEREFORE BE IT RESOLVED THAT the Council of the Town of Shelburne formally opposes the proposed changes to Freedom of Information laws contained within the provincial omnibus budget bill;

AND THAT Council calls on the Government of Ontario to withdraw or amend the legislation to preserve strong transparency and accountability measures;

AND THAT the Province be urged to restore full legislative committee review and provide meaningful opportunities for municipal and public consultation on all components of the bill;

AND THAT a copy of this resolution be forwarded to the Premier of Ontario, the Minister of Finance, the Minister of Municipal Affairs and Housing, the local Member of Provincial Parliament, and relevant municipal associations including the Association of Municipalities of Ontario;

AND THAT this resolution be circulated to neighbouring municipalities within Dufferin County for endorsement.

CARRIED, W. Mills

Requested Vote to be recorded [X] Yes [] No

	Yea	Nay	Absent
Mayor Mills	[X]	[]	
Deputy Mayor Hall	[X]	[]	
Councillor Benotto	[X]	[]	
Councillor Fegan	[X]	[]	
Councillor Guchardi	[X]	[]	
Councillor Sample	[]	[]	X
Councillor Wegener	[X]	[]	



May 20, 2026

Via: Email

Sarah Culshaw
Treasurer
Township of Melancthon
157101 Highway No. 10
Melancthon ON L9V 2E6

Dear Sarah:

Re: Drainage Superintendent Services
File No.: D-ME-SUP
Project No.: MSO019743.2026

As we are now into the second quarter of the business year, we would appreciate updating our account for Professional Services. The enclosed invoice covers the time period from January 1, 2026, through March 26, 2026.

The work undertaken during this period includes the following:

January 2026

- Completed application for OMAFA Grant on the Costs of Employing a Drainage Superintendent in 2025. Uploaded completed application along with supporting documentation to the Transfer Payment Ontario (TPON) website.

February 2026

- Prepared and forwarded an invoice summary for the completed maintenance work on the Stewart Drainage Works to Township staff. Subsequent discussion to confirm that the balance aligned with Township records.
- Requested and received updated ownership information for the Stewart Drainage Works watershed from Township staff, including clarification of several property ownership details.
- Completed the apportionment of the maintenance costs for the work completed in 2024 and 2025 on the Stewart Drainage Works. Subsequently, prepared and forwarded a draft Maintenance Levying By-law along with an accompanying assessment schedule for levying of the maintenance costs.

- Received a request from Martin Drainage on behalf of property owner Norman Bauman (Lot 22, Concession 4 N.E.) regarding the recommended culvert size for the Broster Drainage Works. Provided the Contractor with the *Minimum Recommended Sizes for Farm Culverts* extracted from the 1982 Engineer's report, together with the Armtec supply list identifying the pipe arch option with equivalent hydraulic capacity, including the recommended corrugation profile and wall thickness. Further provided a recent quotation from an Armtec supplier for this pipe arch option.
- Completed OMAFA Grant Allocation Request for the costs of employing a Drainage Superintendent. Uploaded completed application to the Transfer Payment Ontario (TPON) website.

March 2026

- Correspondence with tenant farmer Leo Blydorp & property owner Timothy Frey regarding crop schedule and timeline for the remaining levelling work on the Gray Municipal Drain. Received confirmation from Timothy Frey that the excavated material on his property (Lot 16, Concession 6 S.W.) has been removed, and as such, no further work on the drain is required on his property.
- Discussion with trapper Dave Cowen regarding trapping sites from fall 2025 that were put on hold due to winter conditions. Further discussed the process for trapping under the 2026 Dufferin County Nuisance Beaver Program.

As you are aware, the cost of employing a Drainage Superintendent is eligible for a 50% grant. The Ministry has requested that the grant application be submitted yearly. As such, the application will be completed for you at year's end.

Should you have any questions or if we can be of any further assistance in the meantime, please call.

Yours truly,

R.J. Burnside & Associates Limited

Drainage Superintendent



T.M. Pridham, P.Eng.
Drainage Engineer
TMP:md

Enclosure(s) Invoice No. MSO019743.2026-1

Other than by the addressee, copying or distribution of this document, in whole or in part, is not permitted without the express written consent of R.J. Burnside & Associates Limited.



R.J. Burnside & Associates Limited
 15 Townline
 Orangeville, ON L9W 3R4
 Phone: (519) 941-5331 Fax: (519) 941-7721
 www.rjburnside.com

Township of Melancthon
 157101 Highway 10
 Melancthon, ON L9V 2E6

14 April 2026
 Invoice No: MSO019743.2026 - 1

ap@melancthontownship.ca

Project MSO019743.2026 D-ME-SUP-2026

Professional Services through 26 March 2026

	Hours	Amount	
Senior Engineer II			
Pridham, Thomas	7.50		
Tech VI			
Douglas, Myles	23.80		
Project Support III			
Olmstead, Amanda	.40		
Totals	31.70		
Total Labour			5,007.80
Misc Reimbursable Expense		21.76	
Total Reimbursables		21.76	21.76
HST #885871228	13.00 % of 5,029.56	653.84	
Total Tax		653.84	653.84
	Total Amount Due in CDN Funds	<u><u>\$5,683.40</u></u>	

Billings to Date

	Current	Previously	Billed to Date
Labor	5,007.80	0.00	5,007.80
Expense	21.76	0.00	21.76
Tax	653.84	0.00	653.84
Totals	5,683.40	0.00	5,683.40

Project Manager: Thomas Pridham

Client Number: 61

Please reference your billing client number when making payments via direct deposit or electronic transfer.

To pay via e-Transfer please use etransfers@rjburnside.com as payee.

When paying by electronic means, please check that Burnside address and banking information is entered correctly. Be alert to potential scams suggesting a change in our banking information.

Payment terms are net 30 days. Late payments are subject to a penalty of 1.5% per month (18% annually).



RECEIVED

MAY 22 2026

Sylvia Jones MPP
Dufferin-Caledon

180 Broadway, 3rd Floor, Suite A
Orangeville, ON. L9W 1K3
Tel: 519-941-7751
Toll Free: 1-800-265-1603
Email: sylvia.jones@pc.ola.org

May 15th 2026

Mayor Darren White & Members of Council
Township of Melancthon
157101 Highway 10, Melancthon, ON L9V 2E6

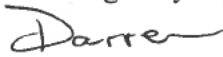
Dear Mayor White,

I am writing to share that our government is proposing changes to the Police Record Checks Reform Act, 2015, to help reduce wait times for police record checks across Ontario.

The proposed changes would allow designated police services to process vulnerable sector checks for applicants outside their local jurisdiction during periods of high demand, helping improve processing times for employment and volunteer opportunities.

These updates would maintain strong screening standards while helping community organizations, service providers and volunteer groups onboard staff and volunteers more efficiently, particularly those working with children, seniors and individuals with disabilities.

The proposed amendments are part of our government's broader plan to strengthen community safety, support enforcement efforts, and protect victims and vulnerable people across our province.

Sincerely,

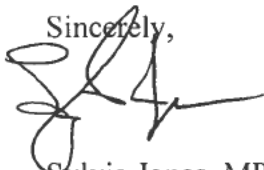

Sylvia Jones, MPP
Dufferin-Caledon

Ministry of the
Attorney General

Office of the Assistant Deputy
Attorney General

Policy Division

McMurtry-Scott Building
720 Bay Street, 3rd Floor
Toronto ON M7A 2S9

Ministère du
Procureur général

Bureau du sous-procureur
général adjoint

Division des politiques

Édifice McMurtry-Scott
720, rue Bay, 3^{ème} étage
Toronto ON M7A 2S9



MEMORANDUM TO: Heads of Council - Ontario Municipalities

DATE: May 22, 2026

FROM: Tom McKinlay,
Assistant Deputy Attorney General

RE: **Follow-up to Updates to “Tailgate Event” Permits** under
the *Liquor Licence and Control Act, 2019*

Further to my earlier letter dated January 13, 2026, I am writing to provide clarification regarding bring-your-own event permits.

What is the change?

Recent amendments to Ontario Regulation 747/21 (Permits) under the *Liquor Licence and Control Act, 2019* (LLCA) introduce a new bring-your-own event permit. This change expands what was previously called the tailgating permit.

This permit allows individuals aged 19 and older to bring and consume their own liquor within a designated area of a cultural or community event that has been approved by a municipality **or** held in connection with, and in proximity to, a professional, semi-professional or post-secondary sporting event.

What action should municipalities take?

Municipalities have the option to designate community or cultural events as eligible for the new bring-your-own event permit. **Importantly, municipalities are not required to designate any events as eligible.**

Event organizers who are interested in the bring-your-own permit will need to approach the municipality where they would like to hold the event and seek designation as a community or cultural event. The government recognizes that municipalities are best positioned to understand local needs and contexts, and therefore to determine whether and how to designate eligible events.

Municipalities may establish their own local processes to determine which events qualify and the form of the municipal designation.

There would be two routes a municipality could take:

- Review each request on a case-by-case basis before their council or;
- Delegate the authority to designate events to a municipal official, such as the clerk

Municipalities that do not wish to allow bring-your-own events may choose to express their position by way of a resolution.

These amendments do not affect existing municipal approval requirements for events held on municipal property (e.g., parks).

What about events tied to sporting events?

Unlike the cultural or community permitting process, bring-your-own events that are held in proximity to a professional, semi-professional or post-secondary sporting event are unchanged and do not require a designation by the responsible municipality.

What action do organizers take once a municipality designates their event as community or cultural?

It is up to event organizers to confirm with the responsible municipality that their event qualifies as a designated cultural or community event.

Once confirmed, organizers may apply for a bring-your-own event permit through the [iAGCO portal](#). **The AGCO will issue a permit only where the applicant provides proof of municipal designation.**

Why did the Government make this change?

This change is intended to provide greater flexibility for some event organizers, potentially reducing costs and increasing attendance. For example, a movie screening in a municipal park may invite more of a “picnic atmosphere” and thus, organizers may prefer the bring-your-own permit.

The province recognizes that this permit may not be relevant to all. Events that rely on alcohol sales and do not use a bring-your-own model may continue to operate as usual.

What considerations were made for safety?

All permitted events will continue to be subject to the existing health and safety requirements under the LLCA. Permit-holders are responsible for ensuring these standards and requirements.

What if I still have questions?

If you have any questions about these regulatory changes, please contact Armina Samadi, Director, Agency and Tribunal Relations Branch at Armina.Samadi@ontario.ca.

If you have any questions about AGCO permits and the application process, please contact Ruxandra Ilicea, Senior Eligibility Officer at Ruxandra.Ilicea@agco.ca.

Yours truly,



Tom McKinlay
Assistant Deputy Attorney General

c: Armina Samadi
Director, Agency and Tribunal Relations Branch, Ministry of the Attorney General

Leslie Fenton
Director, Corporate Affairs, Governance and Agency Oversight, AGCO

Mulmur Melancthon Fire Department 2025 Annual Report



Prepared by

Fire Chief

Mathew Waterfield

Message from the Fire Chief

I am pleased to present the Mulmur Melancthon Fire Department 2025 Annual Report. This report provides an overview of departmental activity, service delivery, training, equipment investments, and key priorities that supported fire protection and emergency response services throughout the year.

In 2025, the department continued to provide dependable, effective, and responsive service to the residents and visitors of the Townships of Mulmur and Melancthon. Call volume increased over the previous year, and members continued to meet operational demands with professionalism, dedication, and a strong commitment to public safety.

Training and professional development remained a core operational priority. Members continued to work toward and maintain certification in accordance with the Fire Protection and Prevention Act and related standards, helping to ensure that service delivery is supported by appropriate qualifications, operational competence, and safe work practices.

Weekly training was delivered across a range of core disciplines, including auto extrication, rural water supply, emergency medical response, wildland fire suppression, hose advancement, and pump operations. This ongoing investment in training supports operational readiness and helps ensure the department remains prepared to manage a broad range of incidents safely and effectively.

The department also remained focused on responsible asset management through the maintenance of existing apparatus and equipment and continued planning for future capital requirements. Ongoing stewardship of departmental assets remains essential to supporting safe, reliable, and sustainable service delivery across both municipalities.

Public education and community engagement continued to support the department's broader service mandate. Participation in community events, including Melancthon Day at Horning's Mills Park, provided opportunities to promote fire safety awareness, strengthen community relationships, and support public outreach.

In 2026, the department will continue to build on its operational experience and training achievements while advancing key equipment initiatives, including the planned acquisition of a utility task vehicle. This investment is intended to strengthen response capability across the service area and further support assistance to mutual aid partners when required.

Fire Chief

Mathew Waterfield

Members of the Department

Fire Chief

Mathew Waterfield

Deputy Fire Chief

Everhard Olivieri-Munroe

Acting Deputy Chief

Jeff Merkley

Captains

- Brant Squirrell
- Chris Curd
- Michael Mehlhorn

Acting Captain

Kyle McGee

Firefighters

- Tony White
- Mitch Clark
- Dan Henderson
- Jayme Brown
- Aaron McGurik
- Stephanie Martin
- Shane Pritchard
- Luke Elen
- Krista LeDain
- Molly Nicholson
- Kurtis Vanstone

Recruits

- Jacob Macdonald
- Kurtis Sparling
- Devon Doig

Service Delivery and Operational Overview

In 2025, the Mulmur Melancthon Fire Department responded to 130 calls for service, compared with 111 calls in 2024, representing an increase of 19 incidents or approximately 17 per cent. The highest-volume incident types continued to be medical assistance responses (48) and motor vehicle collisions (30), reflecting significant operational demand in these areas. During the reporting year, the department responded to 51 incidents in Melancthon and 79 incidents in Mulmur, underscoring the importance of maintaining consistent coverage and response capability across both municipalities.

Overall call volume increased in 2025, and the department continued to respond to a broad mix of incidents requiring sustained operational preparedness. Medical assistance calls and motor vehicle collision responses accounted for a substantial share of total activity and continue to inform training priorities, equipment readiness, and coordinated response practices. The continued frequency of these incident types reinforces the importance of ongoing skills maintenance, scenario-based training, and strong inter-agency coordination in support of effective response outcomes and member safety.

Incident Summary by Response Type

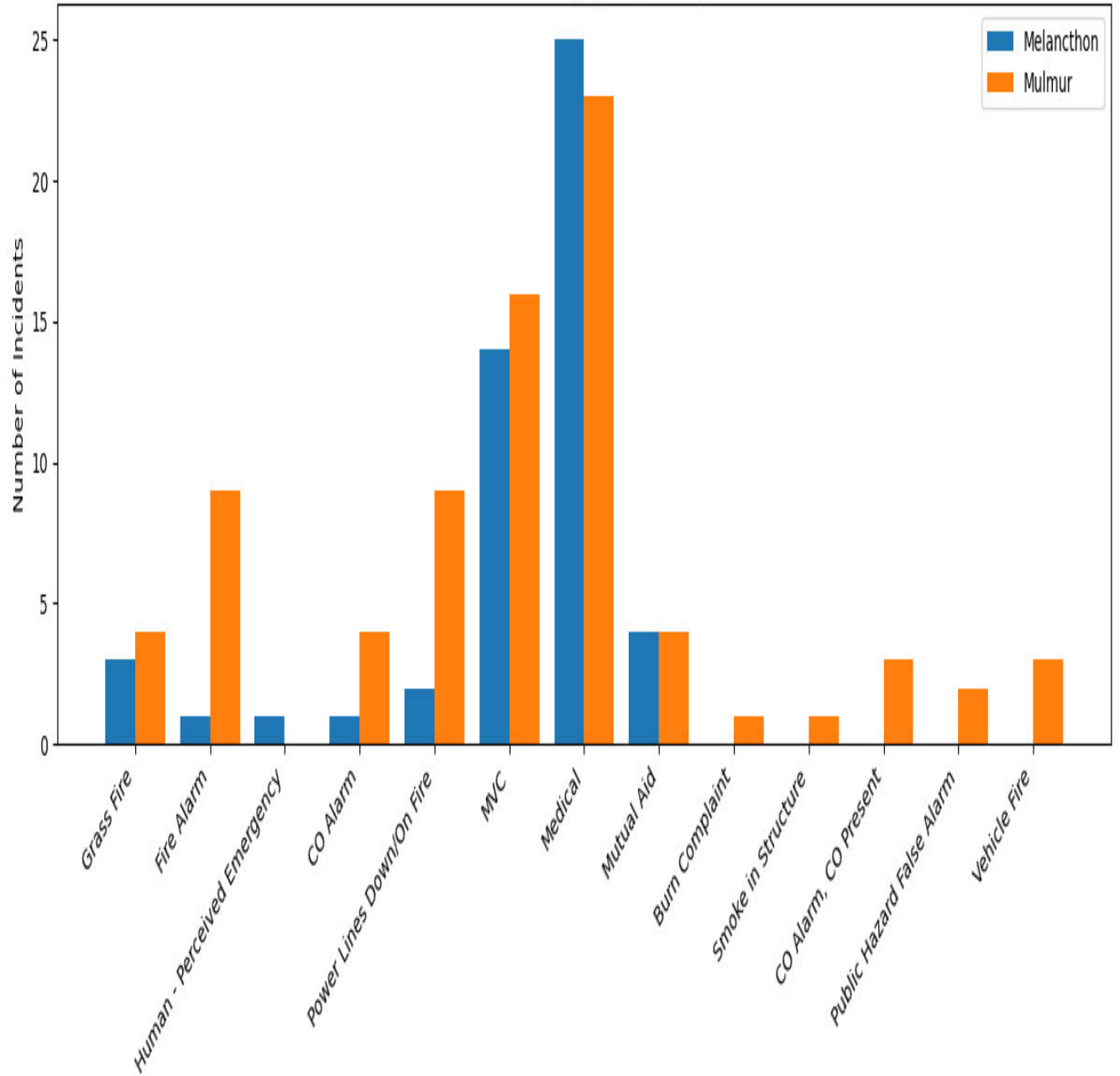

Historical looks at Emergency calls

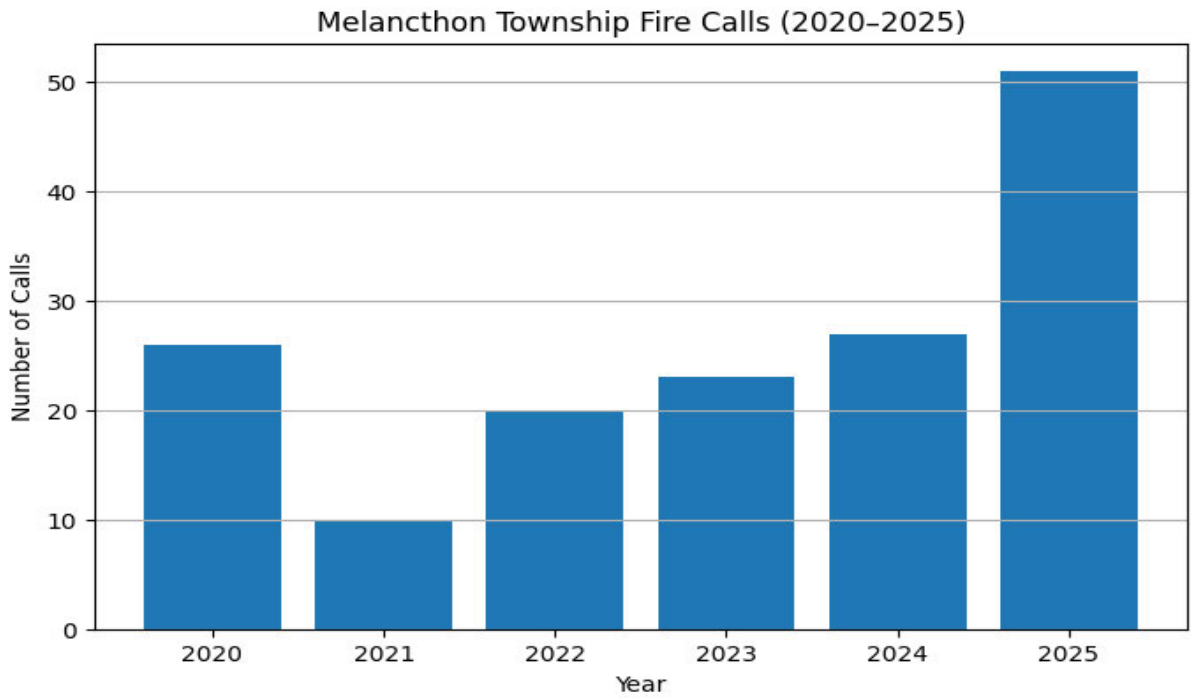
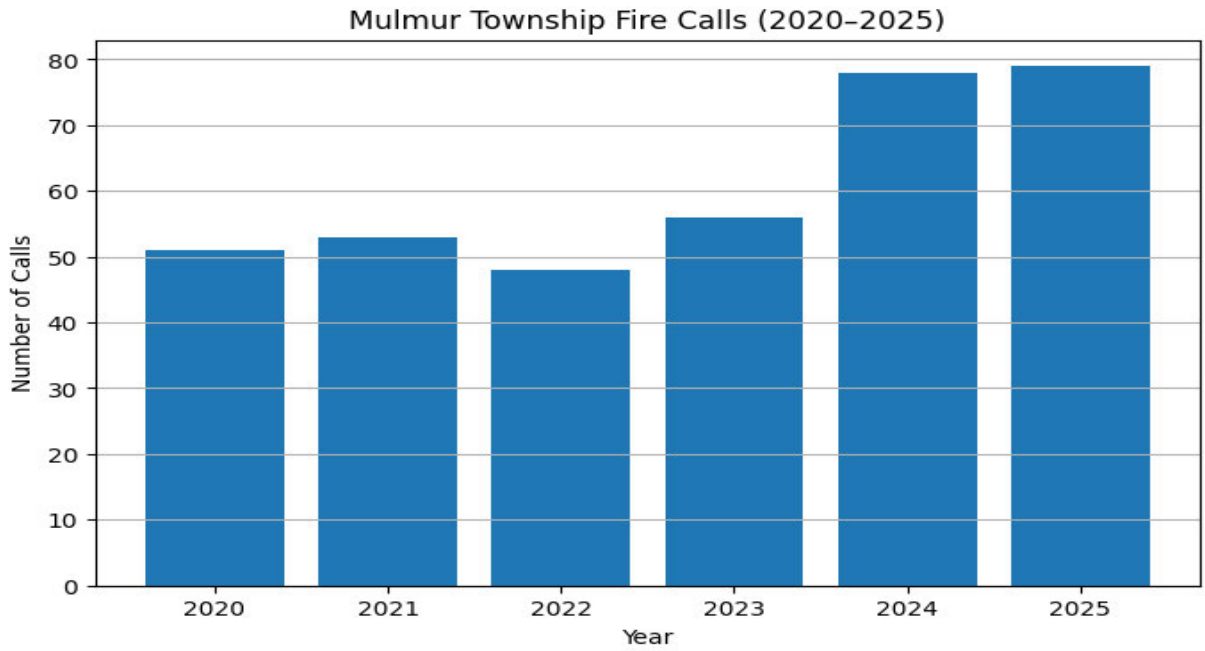

Equipment Investments and Grant Funding

Through the 2025 Fire Service Grant, the department acquired a bunker gear dryer to support personal protective equipment care and operational readiness. The equipment improves the department's ability to clean, dry, and return protective gear to service in a timely manner, particularly following incidents requiring decontamination. This investment also supports the department's ongoing health and safety objectives by strengthening PPE maintenance practices and reinforcing cancer-prevention measures related to the cleaning and handling of contaminated gear.

The department also continued to upgrade existing equipment through approved budget allocations, including the purchase of 15 new Scott SCBA 45-minute cylinders to help maintain firefighter readiness and safety. Additional investments were made in firefighting hose for both structural and wildland incidents in support of ongoing operational requirements.

Strategic Priorities for 2026

- Maintain a training program that continues to emphasize the department's most frequent incident types—particularly medical assistance responses and motor vehicle collisions—while ensuring members remain prepared for a broad range of emergencies.
- Continue reinforcing PPE care, cleaning, and decontamination practices, including consistent use of the new gear dryer, to support member health and safety and to sustain cancer-prevention best practices.
- Monitor call volume and call distribution trends to support operational planning and budget development, with the objective of maintaining effective coverage and response capability across both municipalities.
- Identify and pursue applicable grant and funding opportunities that enhance firefighter safety, support operational effectiveness, and address emerging equipment or capital needs.

The department appreciates the continued support and guidance of the Fire Board. The commitment of all members of the Mulmur Melancthon Fire Department remains fundamental to delivering dependable emergency response services and helping protect the residents, visitors, and property of both municipalities.

Denise Holmes

From: Eowyn Spencer <espencer@grandriver.ca>
Sent: Wednesday, May 27, 2026 11:01 AM
To: Kevin Davis; mayor@guelph.ca; mayor@hamilton.ca; david.bailey@brant.ca; sbentley@haldimandcounty.on.ca; gary.carr@halton.ca; amy.martin@norfolkcounty.ca; mayor@swox.org; kredman@regionofwaterloo.ca; michael.dehn@erin.ca; ssoloman@townofgrandvalley.ca; cgerrits@amaranth.ca; Shawn Watters; Guy Gardhouse; Chris White; g davidson@mapleton.ca; Darren White; toddkasenberg@northperth.ca; Mayor@pertheast.ca; James Seeley; b milne@southgate.ca; alennox@wellington-north.ca
Cc: clerks@brantford.ca; clerks@guelph.ca; clerk@hamilton.ca; clerks@brant.ca; clerksoffice@oxfordcounty.ca; clerk@haldimandcounty.on.ca; clerks@northperth.ca; clerks@norfolkcounty.ca; clerks@halton.ca; regionalclerk@regionofwaterloo.ca; clerks@erin.ca; Meghan Townsend; Nicole Martin; kokane@centrewellington.ca; pavgoustis@eastgarafraxa.ca; aknight@get.on.ca; lwheeler@mapleton.ca; Denise Holmes; acarter@pertheast.ca; admin@puslinch.ca; lgreen@southgate.ca; kwallace@wellington-north.com
Subject: Consolidation of CAs - Transition Committees
Attachments: GM-03-26-32 - Provincial Decision on Environmental Registry Posting 025-1257.pdf; GM-05-26-43 – Eastern Lake Erie Regional Conservation Authority Transition Committee Update.pdf

Greetings Grand River watershed Heads of Council & Clerk's Offices:

Recently you may have received correspondence from the new Ontario Provincial Conservation Agency regarding appointments to the transition committees and we wanted to let you know that the representatives for the GRCA have been appointed. For Grand River, our Board has appointed Chair John Challinor II (Region of Halton) as the elected representative, our CAO Samantha Lawson as the senior staff, with our Deputy CAO as an alternate.

Attached here are our staff reports as they will provide some helpful background info. Our Board members, as the appointed representatives of our participating municipalities, received these reports at our March and May Board meetings, and the recommendations were passed as written.

If there's any additional information we can provide that you may find helpful, please reach out at any time.

Kind regards,

[Eowyn Spencer \(she/her\) hear name](#)
Supervisor of Administrative Services
Grand River Conservation Authority

400 Clyde Road, PO Box 729
Cambridge, ON N1R 5W6
Office: 519-621-2763 ext. 2200
Toll-free: 1-866-900-4722

www.grandriver.ca | [Connect with us on social](#)

Grand River Conservation Authority

Report number: GM-03-26-32

Date: March 27, 2026

To: Members of the Grand River Conservation Authority

Subject: Provincial Decision on Environmental Registry Posting 025-1257

Recommendation:

THAT Report Number GM-03-26-32 – Provincial Decision on Environmental Registry Posting 025-1257 be received as information;

AND THAT the Chair, John Challinor II, be appointed as the Grand River Conservation Authority municipally- elected member to the Eastern Lake Erie Regional Conservation Authority Transition Team Committee.

Summary:

On March 10, 2026, the Ministry of the Environment, Conservation and Parks (MECP) released its decision on Environmental Registry Posting 025-1257, focused on modernizing Ontario's conservation authority system. From GRCA's perspective, the decision reflects a considered approach informed by engagement and feedback. The refinements made reflect an emphasis on local governance, watershed-based decision-making, and municipal participation. Key elements, such as the adjusted regional boundary, updated governance structures, and the commitment to maintain existing programs and services throughout the transition, support continuity and improved coordination.

Report:

On March 10, 2026, the Ministry of the Environment, Conservation and Parks (MECP) released its decision regarding Environmental Registry Posting 025-1257, which focuses on modernizing the province's conservation authority system. The Province confirmed it will move forward with consolidating Ontario's 36 Conservation Authorities (CAs) into nine regional CAs, supported by a newly established Ontario Provincial Conservation Agency (OPCA). The consolidation is targeted for early 2027.

This modernization initiative is intended to strengthen watershed management across Ontario by improving consistency, enhancing technical capacity, and delivering more efficient and accountable permitting and services.

The Province's decision reflects engagement with municipalities, CAs, and other interest holders. Through virtual sessions, regional workshops, and more than 14,000 public comments submitted, input was gathered and directly informed key refinements to the proposal. Notably, the number of regional CAs was increased from seven to nine in response to stakeholder feedback.

The Grand River Conservation Authority's (GRCA) input played an important role in shaping the final size and boundary of the Eastern Lake Erie Regional Conservation Authority (ELERCA). GRCA noted that the originally proposed boundary was too large and could limit meaningful municipal participation and access to local watershed knowledge. In response, the Province revised the boundary to create a more balanced and manageable configuration that better supports effective governance, strengthens local engagement, aligns with watershed needs, and maintains consistency with the existing source protection region. This adjustment will help

sustain collaboration among municipalities while preserving the local knowledge and relationships that are essential to effective watershed management.

The Province has also confirmed that CA programs and services will remain unchanged and continue without disruption throughout the transition, ensuring continuity for municipalities and communities.

Building on this feedback, the Province introduced several additional refinements to strengthen and support the modernization of the CA system, which are expected to deliver positive outcomes. The following highlights some of the more significant changes:

- Under the new model, CAs will remain locally governed, with updated structures to improve coordination, clarity, and fairness in municipal representation. Upper- and single-tier municipalities will have more clearly defined roles in governance and funding.
- Board membership composition rules will be revised and based on each participating municipality's share of the population within the Regional Conservation Authority's (RCA) jurisdiction. Each municipality will be guaranteed at least one representative to ensure smaller municipalities are included. The regulation may also establish limits on overall board size and cap the number of members from any one municipality.
- Each RCA will also establish at least one Watershed Council to provide community-based input on program and service priorities. Membership will be set out in regulation and include Indigenous and sector-specific representation, such as agricultural and commercial (development) interests.

The changes outlined above will require amendments to the *Conservation Authorities Act*, as well as the development of new supporting regulations. It is anticipated that proposed legislative amendments will be introduced in the coming weeks. Staff will bring forward a subsequent report to the Board once these changes have been approved, outlining their implications and any required actions.

The Province has outlined a structured and coordinated approach to support the transition to the new regional conservation authority model, including the following key elements:

- Transition Committees will be established for each new regional authority, with representation from each existing CA within the region. Each authority will be represented by its CAO/General Manager and a municipal elected member from its board. The Transition Committee would be responsible for developing the Transition plan for consolidation. The Province will appoint a Project Executive to chair each Transition Committee, who will also serve as the inaugural CAO of the RCA for up to 24 months. The OPCA will coordinate and oversee the transition committees and process.
- The Province has committed \$3 million in annual funding to the OPCA to support CAs during the transition. In the first two years, this funding will be directed toward transition costs. Following this period, funding will support regional conservation authorities in meeting enhanced program standards established by the OPCA.
- The transition will occur through a statutory amalgamation, with the new Regional Conservation Authority (RCA) replacing existing authorities as the legal entity on the transition date. All assets, liabilities, rights, and obligations of the predecessor authorities will continue, including partnerships, agreements, funding commitments, employees, permit applications, and any ongoing hearings. This approach is intended to ensure service continuity and avoid disruption to relationships with municipalities, agencies, and funding partners.

- The amalgamation process will be governed by the Public Sector Labour Relations Transition Act, which provides a clear, structured, and neutral framework for addressing labour relations matters arising from public sector restructuring.

As with the proposed changes to the CA system, these transition measures are anticipated to be reflected in forthcoming amendments to the *Conservation Authorities Act* and accompanying regulations.

Overall, the Province's decision reflects a measured approach to modernization. The refinements made, particularly the adjustment of regional boundaries and the creation of the Eastern Lake Erie region, demonstrate a clear effort to balance system-wide consistency with the importance of local knowledge, governance, and collaboration. The GRCA is encouraged by this outcome and remains supportive of the direction moving forward.

Financial Implications:

Not applicable.

Other Department Considerations:

Not applicable.

Submitted by:

Samantha Lawson
Chief Administrative Officer

Grand River Conservation Authority

Report number: GM-05-26-43

Date: May 22, 2026

To: Members of the Grand River Conservation Authority

Subject: Eastern Lake Erie Regional Conservation Authority Transition Committee Update

Recommendation:

THAT Report Number GM-05-26-43 – Eastern Lake Erie Regional Conservation Authority Transition Committee Update be received as information;

AND THAT the Grand River Conservation Authority approves the Eastern Lake Erie Regional Conservation Authority Guiding Principles for Transition;

AND THAT the Chief Administrative Officer, Samantha Lawson, be appointed as the Grand River Conservation Authority senior staff member to the Eastern Lake Erie Regional Conservation Authority Transition Team Committee;

AND THAT the Deputy Chief Administrative Officer, Karen Armstrong, be appointed as the alternate for the CAO as the senior staff member to the Eastern Lake Erie Regional Conservation Authority Transition Team Committee.

Summary:

Not applicable.

Report:

Eastern Lake Erie Regional Conservation Authority Transition Update

The Eastern Lake Erie Regional Conservation Authority will be comprised of the Catfish Creek Conservation Authority, Grand River Conservation Authority, Kettle Creek Conservation Authority, and Long Point Region Conservation Authority. February 1, 2027, has been established as the statutory amalgamation date for the regional conservation authorities.

On Monday, April 20, 2026, the Chairs, Vice-Chairs, and General Managers of Catfish Creek, Grand River, Kettle Creek, and Long Point Region Conservation Authorities met at the Long Point Region Conservation Authority administration office to discuss preparations for the Eastern Lake Erie Regional Conservation Authority amalgamation.

The meeting provided an opportunity for high-level organizational introductions and discussion regarding preliminary principles to guide the transition process. Shared concerns identified during the discussions included ensuring that reserves continue to be used for their intended purposes as endorsed by the current Boards, preserving land donations and land holdings within the new regional conservation authority structure, and maintaining strong watershed-based decision-making and local community connections throughout the transition.

Also presented at the meeting were draft guiding principles for the transition of the four Conservation Authorities into the Eastern Lake Erie Regional Conservation Authority. The document outlines seven high-level principles intended to guide the consolidation process:

- Accountable and Transparent Governance
- Fiscal Responsibility
- Commitment to Workforce Stability and Talent Retention
- Service Excellence
- Risk Management and Business Continuity
- Watershed-Based Science Informed Management
- Transparency, Trust and Clear Communication

While the principles are not listed in order of priority, each is considered essential to achieving a successful transition and ensuring these values remain central to all decisions throughout the amalgamation process. The draft Eastern Lake Erie Regional Conservation Authority -Guiding Principles for Transition are attached to this report.

Individually, each Conservation Authority has expressed a desire to protect watershed-based decision-making, programs and services, staff, local decision-making, community connections, and responsible and effective governance. This shared commitment is reflected within the Guiding Principles document and will form the basis for communications with stakeholders moving forward.

The principles are currently being presented to each individual Conservation Authority Board for approval and once approved, will become a joint document used throughout the transition process.

As the Conservation Authorities prepare to establish the Transition Committee, the Chairs and Vice-Chairs from each Conservation Authority remain committed to scheduling future meetings, supported by bi-weekly meetings of the General Managers, to ensure that issues and concerns are identified early and discussed openly in support of a collaborative, informed, and effective transition process.

Additional appointments to the Eastern Lake Erie Regional Conservation Authority

Following Royal Assent of Bill 97 on April 24, 2025, the transition process for the amalgamation and consolidation of regional Conservation Authorities was initiated. As part of the requirements under the legislation, the Grand River Conservation Authority (GRCA) is required to appoint members to the Transition Committee established by Ontario Provincial Conservation Agency (OPCA) to support and coordinate the transition process.

The Transition Committee will play a key role in preparing for the transition, with OPCA providing coordination, resources, tools, and guidance throughout the process. The committee will remain in place until the transition date, at which time it will be dissolved.

In accordance with the legislative requirements, each predecessor authority is required to appoint two representatives to the Transition Committee, including one municipally elected member of the Conservation Authority and one senior staff representative, being the CAO or General Manager, or an alternate if they are unavailable. On March 27, 2026, the Board appointed Chair John Challinor II as the GRCA's municipally elected representative to the Transition Committee.

Accordingly, it is recommended that Samantha Lawson, CAO, be appointed as the senior staff representative for the GRCA on the Transition Committee. Karen Armstrong is recommended to be the alternate representative should the CAO be unavailable to participate. These appointments will ensure the GRCA is appropriately represented and able to actively participate in transition planning and decision-making throughout the amalgamation process.

Financial Implications:

Not applicable.

Other Department Considerations:

Not applicable.

Submitted by:

Samantha Lawson
Chief Administrative Officer

**Ministry of
Municipal Affairs
and Housing**

Office of the Minister

777 Bay Street, 17th Floor
Toronto ON M7A 2J3
Tel.: 416 585-7000

**Ministère des
Affaires municipales
et du Logement**

Bureau du ministre

777, rue Bay, 17^e étage
Toronto (Ontario) M7A 2J3
Tél.: 416 585-7000



234-2026-1416

May 4, 2026

Your Worship
Mayor Annette Groves
Town of Caledon
Annette.Groves@caledon.ca

Dear Mayor Groves:

I understand that the Town of Caledon, under the direction of Council, has prepared a draft amendment to its Official Plan that would reinstate mineral aggregate-related policies that were altered or removed by the Ministry in its decision on Official Plan Amendment 1 on January 6, 2026.

The decision to approve Official Plan Amendment 1, with modifications, followed a detailed review of the Town's proposed policies to ensure they align with provincial policy, plans, and legislation. This work was done in consultation with partner ministries, including the Ministry of Natural Resources and Ministry of Environment, Conservation and Parks. The decision is final and not subject to appeal. The Ministry therefore expects the Town to implement the mineral aggregate policies now in force, as approved through Official Plan Amendment 1, without further changes.

Provincial policy, plans and legislation, including the Provincial Planning Statement, 2024 and *Aggregate Resources Act*, recognize the importance of protecting mineral aggregate resources and managing their extraction in a balanced way that limits social, economic, and environmental impacts. Materials such as sand, gravel and cement are essential to Ontario's construction sector and are critical for building homes and the infrastructure that supports them.

Ontario's planning framework also recognizes the role of municipalities in making these resources available close to where they are needed. This supports shared provincial and municipal objectives of increasing housing supply and affordability, growing the economy, and creating jobs. The Town's proposed amendment would work against these objectives.

.... /2

I strongly recommend that the Town withdraw its proposed amendment and proceed with implementation of its current Official Plan, including the mineral aggregate policies approved through Official Plan Amendment 1. If the Town does not do so, the Ministry may need to take further action to protect provincial interests.

Thank you for your continued commitment to our shared goals of increasing housing supply, supporting economic growth, and building strong, prosperous communities.

Sincerely,

A handwritten signature in blue ink that reads "Robert J. Flack". The signature is fluid and cursive, with a long horizontal stroke at the end.

Hon. Robert J. Flack
Minister of Municipal Affairs and Housing

- c. Nathan Hyde, Chief Administrative Officer, Town of Caledon
Nathan.Hyde@caledon.ca
Robert Dodd, Chief of Staff, Ministry of Municipal Affairs and Housing (MMAH)
Martha Greenberg, Deputy Minister, MMAH

Denise Holmes

From: Ritchie, Danielle (MNR) <Danielle.Ritchie@ontario.ca>
Sent: Friday, May 15, 2026 10:18 AM
To: Nicole Vankooten; Planning Dept; building@dufferincounty.ca; Planner; Denise Holmes
Cc: Spencer, Lorelie (MNR); Frimpong, Jesse (MNR)
Subject: Request for Comments | APP-2026-00101 | 518693 County Rd 124
Attachments: Request For Comments - APP-2026-00101.pdf

Good morning,
Attached please find the Request for Comments for NEC Application APP-2026-00101.
Comments are requested via email to nec@ontario.ca on or before June 15, 2026.

Kindly contact Lorelie Spencer at lorelie.spencer@ontario.ca should you have any questions.

Thank you,

Danielle Ritchie

Administrative Support Coordinator | Niagara Escarpment Commission
1450 7th Avenue, Owen Sound, Ontario N4K 2Z1
226-668-5672 | www.escarpment.org



Niagara Escarpment Commission

An agency of the Government of Ontario

As part of providing accessible customer service, please let me know if you have any accommodation needs or require communication supports or alternate formats.

The NEC offices are now open to the public in a limited capacity. In order to ensure a safe and secure environment for staff and clients, the NEC **requires** that you make an appointment to meet with staff in person. Alternatively, the NEC will continue to provide services via telephone and email. Updates can be found on our website: <https://escarpment.org/appointments>

Did you know: You can now submit Development Permit Applications to the Niagara Escarpment Commission online? Visit our [website](#) to learn more

**Niagara Escarpment
Commission**
232 Guelph Street
Georgetown, ON L7G 4B1
Tel. No.: 905-877-5191

1450 7th Avenue East
Owen Sound, ON N4K 2Z1
Tel. No. (519) 371-1001

nec@ontario.ca
<https://escarpment.org>

**Commission de l'escarpement du
Niagara**
232, rue Guelph
Georgetown ON L7G 4B1
No de tel. 905-877-5191

1450 7^e avenue Est
Owen Sound, ON N4K 2Z1
No de tel. (519) 371-1001

nec@ontario.ca
<https://escarpment.org>



Niagara Escarpment Commission
An agency of the Government of Ontario

Date: 05/15/2026

Via Email

Nottawasaga Valley Conservation Authority
Dufferin County
Township of Melancthon
Saugeen Ojibway Nation

Request for Comments

File Number: APP-2026-00101

Landowner: Albert Muder

Applicant or Agent: Albert Muder

Legal Description: CON 1 OS W PT LOT 32

Civic Address: [REDACTED]

Assessment Roll Number: 22190000020200000000

Proposed Development:

To demolish an existing accessory structure (shed) and construct a new 1 storey ± 111.5 sq m (1200 sq ft) accessory structure (shed) with a maximum height of 4.9 m (16 ft) on an existing ± 3.0 ha (7.4 ac) lot.

Review and Comment:

The attached Development Permit application, which is summarized above, is being sent to you for review. Your comments and recommendations are requested for the Niagara Escarpment Commission's consideration.

We would appreciate receiving your comments via email by 06/15/2026. If you require additional time to provide comments, please contact us soon as possible.

If you have any questions, please contact Lorelie Spencer at lorelie.spencer@ontario.ca.

Sincerely,

Planning Team,
Niagara Escarpment Commission

FILE # _____

(For NEC office use only)

NIAGARA ESCARPMENT DEVELOPMENT PERMIT APPLICATION

(FMS #0113 - Revised August 15, 2019)

THE NIAGARA ESCARPMENT PLANNING AND DEVELOPMENT ACT, RSO, 1990, AS AMENDED

NIAGARA ESCARPMENT COMMISSION
232 Guelph Street, 3rd Floor
Georgetown, ON L7G 4B1

Phone: 905-877-5191
Fax: 905-873-7452
Website: www.escarpment.org
Email: necgeorgetown@ontario.ca

Serving the areas of:

Dufferin County (Mono)
Region of Halton
Region of Peel
Region of Niagara
City of Hamilton

NIAGARA ESCARPMENT COMMISSION
1450 7th Avenue
Owen Sound, ON N4K 2Z1

Phone: 519-371-1001
Fax: 519-371-1009
Website: www.escarpment.org
Email: necowensound@ontario.ca

Serving the areas of:

Bruce County
Grey County
Simcoe County
Dufferin County (Mulmur, Melancthon)

- Please ensure that the information you provide in this application is complete and accurate.
- Incomplete or inaccurate information will delay the processing of your application.
- Please contact your local Commission office if you have any questions about your proposal or this application.

1. OWNER (Required)

Name: ALBERT MUDER

Mailing Address: _____
Street/P.O. Box

City/Town Ontario Province _____ _____ Postal Code

Phone: _____ E-mail: albertmuder76@gmail.com

2. APPLICANT or AGENT (if applicable)

Name: same as above

Mailing Address: _____
Street/P.O. Box

City/Town _____ Province _____ Postal Code

Phone: _____ E-mail: _____

3. PROPERTY LOCATION & INFORMATION

Municipality: MELANCTON Civic/Street Address #: _____
(Fire/Emergency #)

Lot: WEST PT LOT 32 Concession: 1 OS and/or Lot: _____ Plan: _____

Assessment roll number or PIN: 22-19-000-002-020000-0000 Lot Size: 7.4 ACRES

Date the property was purchased or future date of purchase: 05/15/2017

4. PROPERTY SERVICING

Existing Road Frontage: Municipal Private
Existing Water Supply: Municipal Private
Existing Sewage Disposal: Municipal Private

Proposed Road Frontage: Municipal Private
Proposed Water Supply: Municipal Private
Proposed Sewage Disposal: Municipal Private

5. EASEMENTS, COVENANTS, AGREEMENTS

Describe the type and terms of any easements, right-of-ways, covenants, agreements or other restrictions registered on or affecting the title of the property and/or attach a copy:

None

6. EXISTING & PROPOSED DEVELOPMENT

Note: "Development" includes the construction of buildings and structures, alterations to the landscape, (e.g: placing fill, drainage alterations, pond construction or alteration), any change of use or new use (e.g: residential to commercial, new home business, etc.). If additional space is required, please include a separate attachment.

Briefly Describe the current use of the property and any existing buildings, structures, or alterations to the landscape:

Existing property has a single detached residence with 2 out buildings. One of the two existing sheds is to be demolished and replaced with a new slightly larger building in approx. the same location

Briefly Describe any proposed changes to the use of the property and any proposed new buildings, structures, or alterations to the landscape:

No proposed changes to the use of the property

Note regarding Sections 7-14:
Depending on the type or nature of the proposed development and/or the characteristics of the property, supporting information such as Environmental Impact Studies, Landscape Plans, Lighting Plans, Visual Assessments, Grading Plans, Erosion Control Plans, Slope Stability Studies, etc., may be required in support of the following information.

7. LOT CREATION

If this application involves the creation / severance of a new lot, please provide the following information:

<p>i) Existing Lot:</p> <p>Frontage <u>911 ft</u></p> <p>Depth <u>374 ft</u></p> <p>Size <u>7.4 acres</u></p>	<p>ii) Proposed Lot:</p> <p>Frontage _____</p> <p>Depth _____</p> <p>Size _____</p>	<p>iii) Retained Lot:</p> <p>Frontage _____</p> <p>Depth _____</p> <p>Size _____</p>	<p>iv) Use of new Lot</p> <p><input type="checkbox"/> Agricultural</p> <p><input type="checkbox"/> APO</p> <p><input type="checkbox"/> Commercial</p> <p><input type="checkbox"/> Conservation</p> <p><input type="checkbox"/> Industrial</p> <p><input type="checkbox"/> Lot Addition</p> <p><input type="checkbox"/> Recreational</p> <p><input type="checkbox"/> Residential</p>
---	---	--	---

8. CONSTRUCTION DETAILS

PLEASE NOTE

Ground Floor Area: The total exterior measurements of any building, including attached garages and enclosed decks (as applicable).

Total Floor Area: Is based on the exterior measurements of the building and includes the total of the ground floor area (including attached garages, etc), plus walkout basements, plus full or half second storeys, etc.

Maximum Height: is measured from the lowest grade (e.g., walkout side), to the peak of the roof.

Please provide a description of all existing and proposed development in the following fields:

Use of Structure	Existing, Proposed, or to be Demolished	Ground Floor Area (footprint)	Total Floor Area (all storeys and walkouts)	# of Storeys	Maximum Height (lowest grade to peak)
Storage	Shed (demo)	16x24	384 ft2	1	12'
Storage	Shed (remain)	14x22	308 ft2	1	12'
Residential	House	45x24 irreg	928 ft2 x 2 (Walkout)	2	21'
Storage	New Shed	30x40	1200 ft2	1	16'

Amount of fill to be imported to facilitate the proposed development (if required): _____

9. ACCESSORY FACILITIES, STRUCTURES, FILLING, GRADING, UTILITIES, INFRASTRUCTURE etc.

(e.g: Driveways, Decks, Gazebos, Swimming Pools, Tennis Courts, Lighting, Signs, Wind Turbines, Solar Panels, Hydro Poles/Lines, Retaining Walls, Placement of Fill, Cutting and Filling, Grading, Berms, Parking Areas, Tree/Site Clearing, etc.) (See next page for Ponds)

Describe and provide information such as: dimensions, size, height, amount of fill etc.

Existing driveways to remain

10. HOME BUSINESS, CHANGE OF USE, NEW USE

(e.g): Establishing a **Home Business, Home Occupation, Home Industry** or **Bed and Breakfast** business. Converting or changing the use or establishing a new use on a property or within any dwelling building or structure on a property.)

Describe the proposed business or new use and **provide information** such as:

Type of business or use, size or area of building &/or land to be occupied or altered by the use, construction or alteration details, number of employees, access, parking, storage details, sales, hours of operation, signage, etc.

Note: A separate, detailed, business overview or plan should be provided.

11. PONDS – NEW POND / EXISTING POND WORK – DREDGING, MAINTENANCE, REPAIR etc.

The following information is the minimum information that is required for pond construction or alteration/maintenance. Generally, a hydrology/hydrogeology report and/or an environmental impact assessment is also required.

Pond is: Proposed Existing
Use of Pond: Recreation Irrigation/farm Other Noisy River
Water Source: Offline (Precipitation/run-off) Online (stream, groundwater)
Size of Pond: Water Surface Area 15,000 sqft Depth of Water 8'

Provide a description of the proposed pond related development:

No work done to existing pond

Note: Additional construction details including inflow, outflow, emergency outflow, spillway details, type of construction, height and width of banks, erosion/sediment control measures, placement of excavated materials, and finished grading and landscaping should be shown on the submitted site plan and building details.

12. AGRICULTURAL DEVELOPMENT

Indicate and describe if your proposal involves agricultural land or uses such as:

On-farm Diversified Uses, Agricultural Related Uses, Dwelling Units Accessory to Agricultural Uses, New Dwelling in Agricultural Areas (near barns – MDS I), Livestock Facilities (MDS II), Equestrian Facilities (arenas, riding rings, events), Farm Ponds, Winery and Winery Events, 'Agricultural Purposes Only' (APO) lot creation:

Note: Additional detailed information may be required.

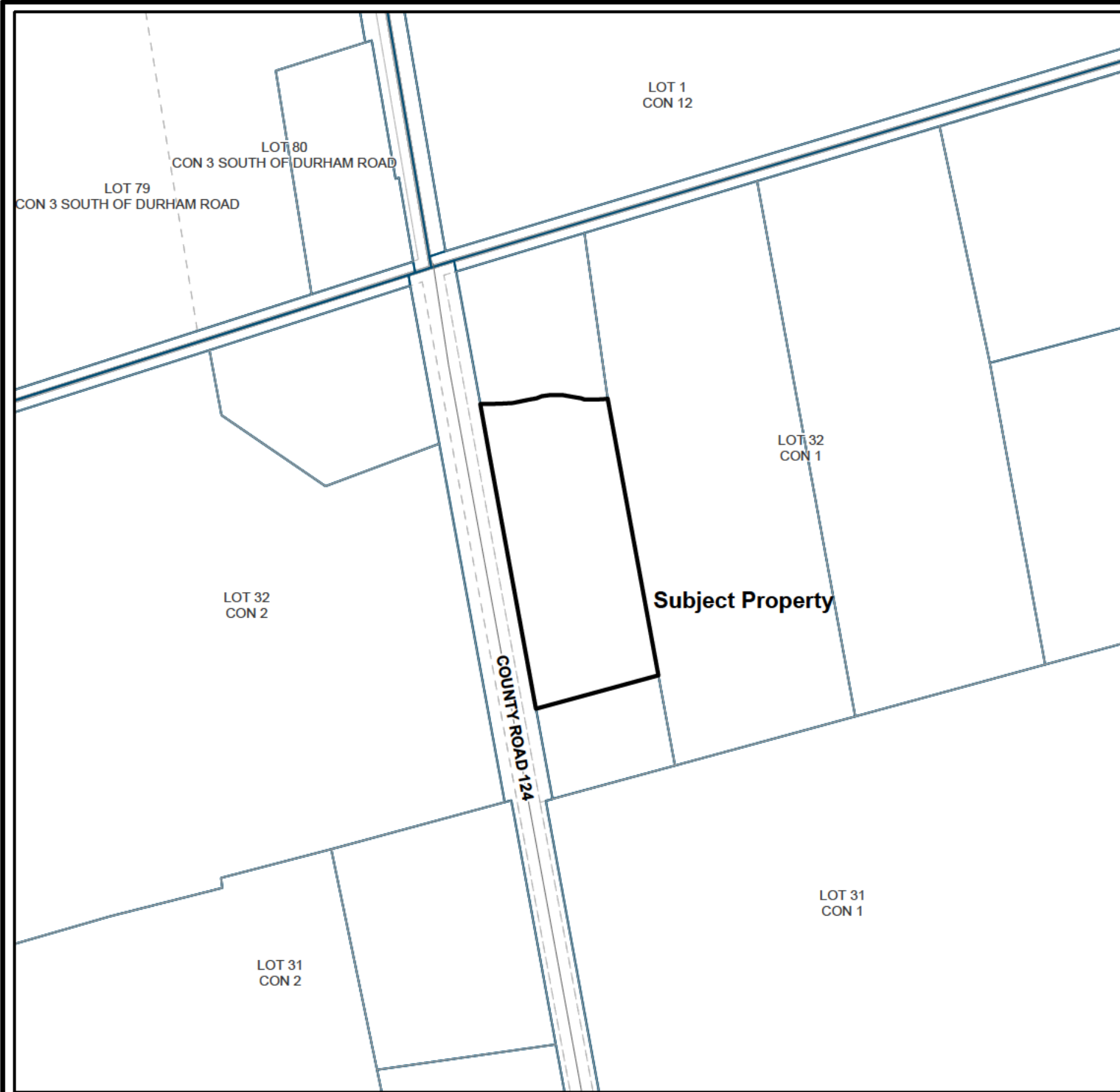

Map 1A
Niagara Escarpment Plan
 518693 County Rd 124, Melancthon
 APP-2026-00101

- Subject Property
- Roads
- Upper Tier Municipality
- Lower/Single Tier Municipality
- Lot and Concession Boundary
- Parcel Boundary
- Ownership Boundary

NOTE: The Niagara Escarpment Plan Designation boundaries shown on this map are approximate and subject to confirmation through Site Inspection and the application of the 'Interpretation of Boundaries' section of the Niagara Escarpment Plan

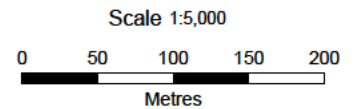

Printed on: 2026-05-12

THIS IS NOT A PLAN OF SURVEY.
 This map is illustrative only. Do not rely on it as being a precise indicator of routes, location of features, nor as a guide to navigation. Base derived from various sources.
 Map compiled and produced by the Geographic Information Systems (GIS) Department of the Niagara Escarpment Commission, Ministry of Natural Resources



© King's Printer for Ontario and its licensors. [2026]
 May Not be Reproduced without Permission.



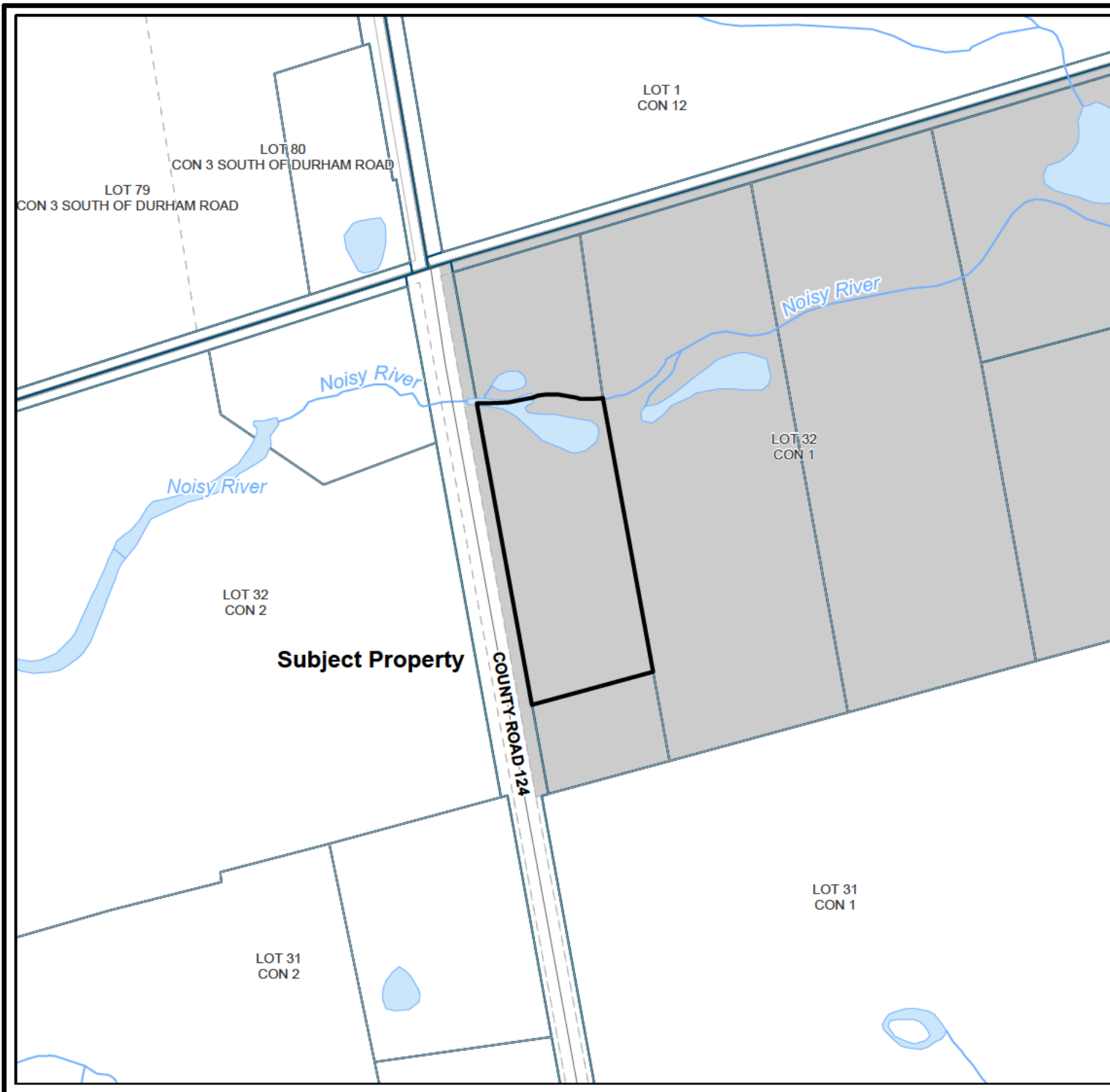

Map 2

Lot Configuration

518693 County Rd 124, Melancthon
APP-2026-00101

- Subject Property
- Area of Development Control
- Roads
- Waterbodies
- Watercourse
- Upper Tier Municipality
- Lower/Single Tier Municipality
- Lot and Concession Boundary
- Parcel Boundary
- Ownership Boundary

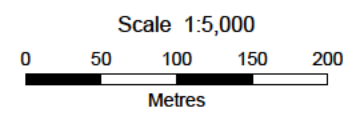

Printed on: 2026-05-12
THIS IS NOT A PLAN OF SURVEY.
This map is illustrative only. Do not rely on it as being a precise indicator of routes, location of features, nor as a guide to navigation. Base derived from various sources.
Map compiled and produced by the Geographic Information Systems (GIS) Department of the Niagara Escarpment Commission, Ministry of Natural Resources

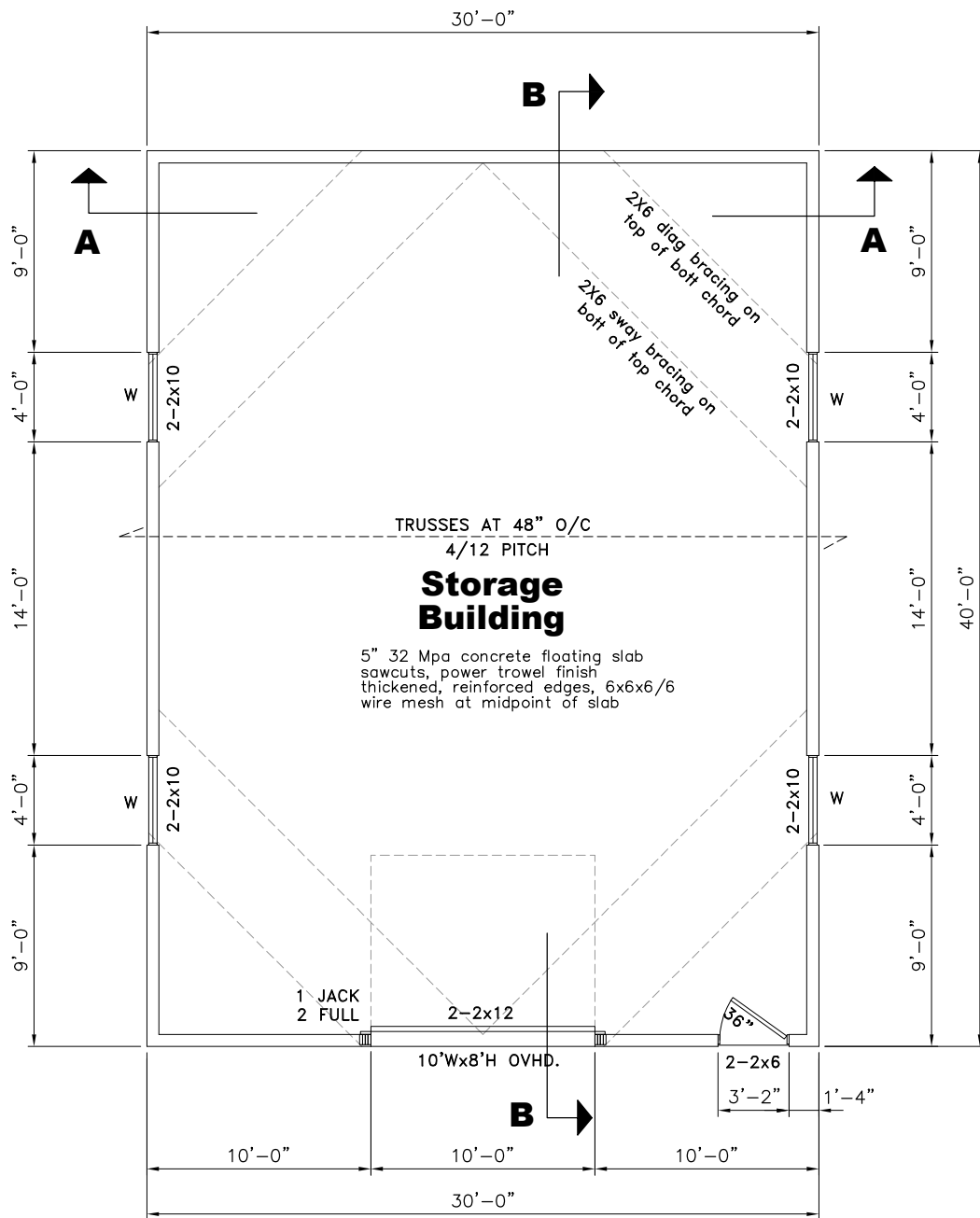

FLOOR PLAN

SCALE: 1/8" = 1'-0"

CONFIRM WINDOW AND DOOR
RSO'S WITH SUPPLIER

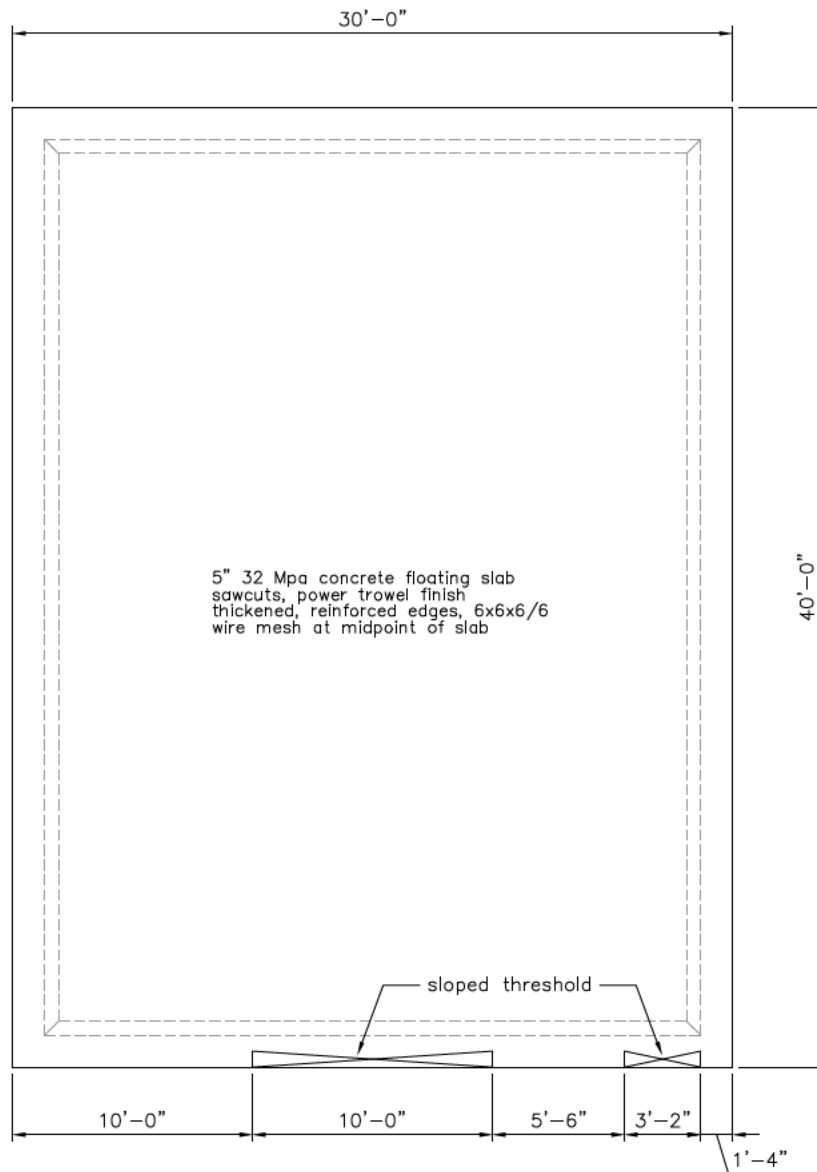

FOUNDATION - FLOATING SLAB

SCALE: 1/8" = 1'-0"

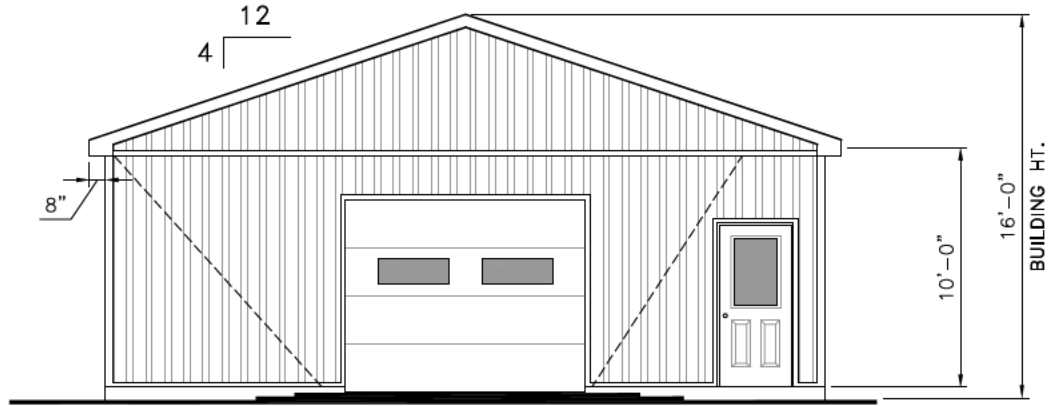

FRONT ELEVATION

SCALE: 1/8"=1'-0"

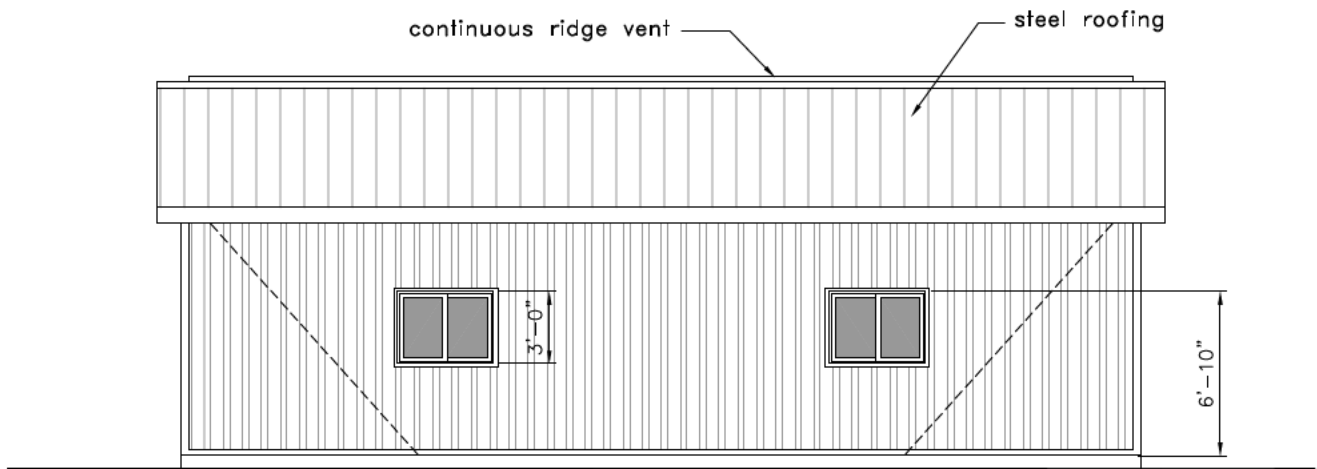

LEFT /RIGHT SIDE ELEVATION

SCALE: 1/8"=1'-0"

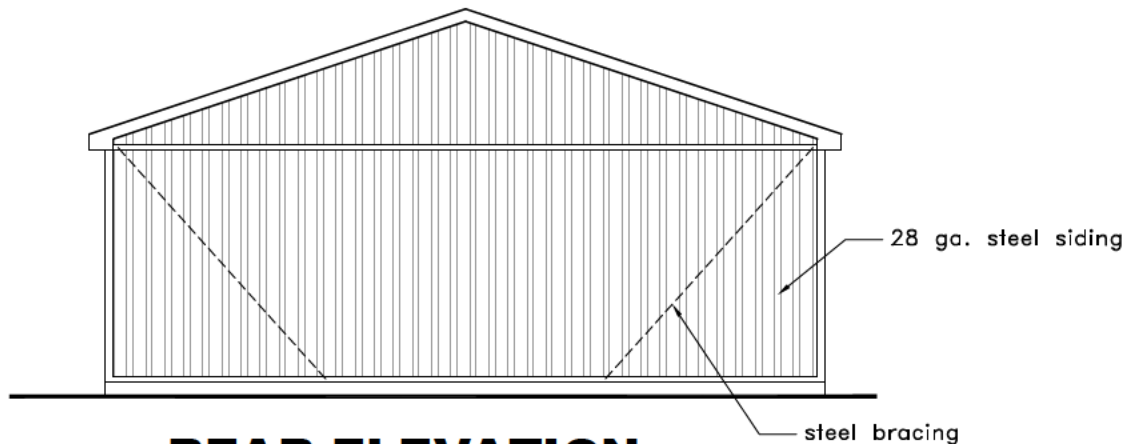

REAR ELEVATION

SCALE: 1/8"=1'-0"

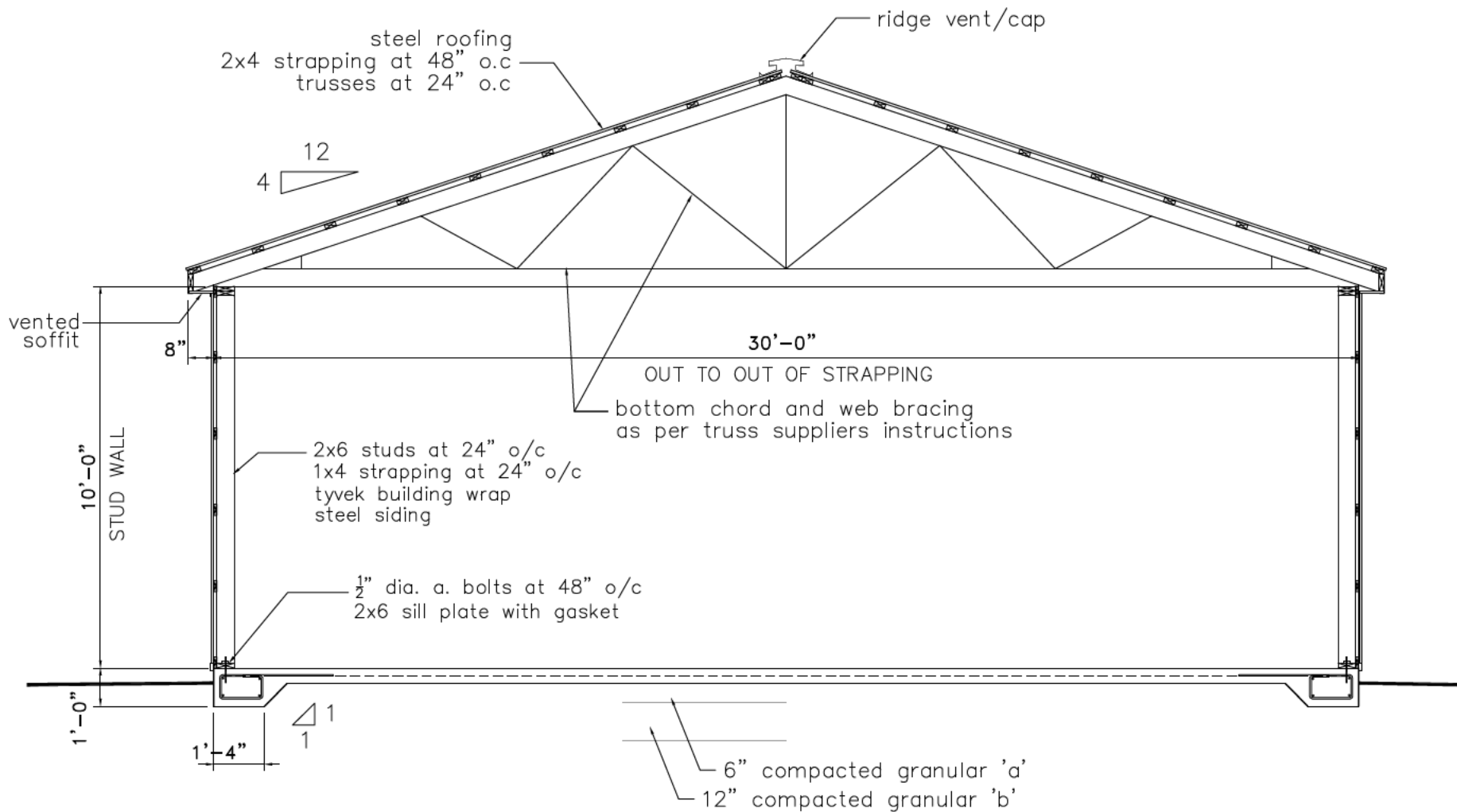

Building Section A-A

SCALE: 1/4"=1'-0"

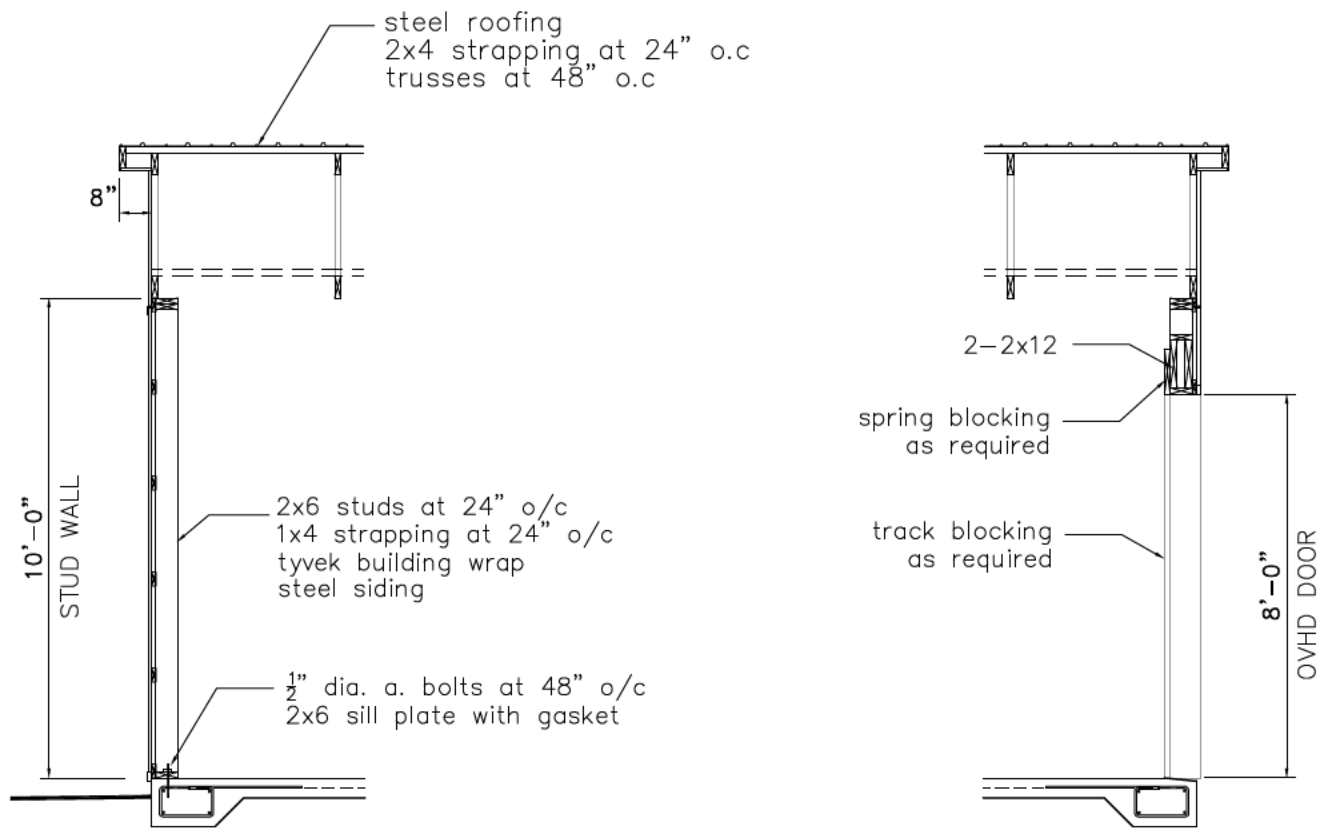

Building Section B-B

SCALE: 1/4"=1'-0"



3/27/2026, 4:34:48 PM

-  Dufferin County Building Footprints
-  Assessment Lot Parcels

Site Plan

518693 Cty Road 124 Melancton
7.4 acres

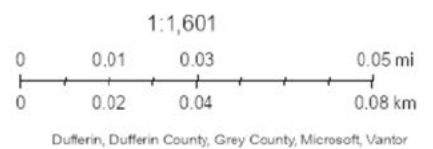

Denise Holmes

From: Denise Holmes
Sent: Friday, May 22, 2026 1:10 PM
To: Denise Holmes
Subject: FW: Hall board

----- Forwarded message -----

From: sue shier [REDACTED]
Date: Fri, May 22, 2026 at 12:24 PM
Subject: Re: Hall board
To: Ruth [REDACTED]

MAY 24/
Hornings Mills Hall Board

Resignation

Please note that effective immediately I, Sue Shier
Am resigning my position on the Hall Board.

Sue Shier



CORPORATION OF THE TOWNSHIP OF MELANCTHON

COUNCIL MOTION

Date: June 4, 2026

Moved by _____

Seconded by _____

Be it resolved that:

WHEREAS on May 13, 2026 the CAO/Clerk of the Township of Melancthon received written notification from Councillor Ralph Moore of his resignation from Council, effective June 1, 2026;

AND WHEREAS Council accepts Mr. Moore’s resignation and wishes to express its sincere appreciation for his years of service and dedication to the Township of Melancthon, including his contributions to the various Boards and Committees on which he served;

NOW THEREFORE BE IT RESOLVED THAT pursuant to Section 262(1) of the Municipal Act, 2001, as amended, the Council of the Township of Melancthon hereby declares the Office of Councillor vacant.

Requested Vote to be Recorded [] Yes [] No

	Yea	Nay	Absent
Mayor White	[]	[]	[]
Deputy Mayor McLean	[]	[]	[]
Councillor Neilson	[]	[]	[]
Councillor Plowright	[]	[]	[]

CARRIED/LOST _____
MAYOR DARREN WHITE

Memorandum

To: The Council of the Township of Melancthon
Attn: Denise Holmes

From: Stutz Brown & Self Professional Corporation
Attn: Steve Christie

Date: May 26, 2026

Re: Council Vacancy — Resignation of Councillor Ralph Moore and Obligation to Fill Vacancy by Appointment

I understand that Councillor Ralph Moore has resigned his Council seat effective June 1, 2026. Council has asked for an opinion on whether it may leave the seat vacant, given the short period remaining in the term, and whether Council, if it proceeds with an appointment process, may impose the stipulation that those who have already filed nomination papers for the 2026 municipal election may not apply for the appointment.

Obligation to Fill Vacancy

Legally, Council should not intentionally leave the seat vacant. Under the Municipal Act, Council is required to declare the seat vacant at its next meeting after the vacancy occurs and to fill the vacancy by appointment within the statutory deadline which is within 60 days of Council declaring the seat to be vacant (prior to Aug. 4, 2026, given that Aug. 3 is a statutory holiday). Further, it should be noted that the 90-day exemption for filling a vacancy is not applicable as the election is more than 90 days from the date of the declaration of vacancy. Further, the statutory language is mandatory - Council “shall” fill the vacancy within the applicable period. The legislation does not give Council discretion to leave a seat vacant because the remaining term is short or because the appointment may be politically sensitive.

A deliberate decision not to fill the vacancy would create legal risk. That risk could include an application seeking declaratory relief or a Court Order compelling Council to perform its statutory duty.

This does not mean that Council must appoint a person regardless of the circumstances. If Council undertakes a proper process and receives no eligible applicants, or if an unusual circumstance arises that prevents an appointment, Council’s position would be different. However, Council should be able to demonstrate that it made reasonable, transparent, and good-faith efforts to comply with the Act.

Imposition of Stipulation

Council also should not impose the proposed stipulation that those who have already filed nomination papers for the 2026 municipal election may not apply for the appointment as a condition of eligibility.

A person who has filed nomination papers cannot be disqualified on that basis under the Municipal Act or the Municipal Elections Act. Council may require disclosure of this and may consider it as part of a broader assessment of the appointment.

The qualifications for municipal office are set by statute and generally, a person is eligible to hold municipal office if the person is:

- a Canadian citizen;
- at least 18 years old;
- a resident of the municipality, an owner or tenant of land in the municipality, or the spouse of such an owner or tenant; and
- not otherwise disqualified by legislation.

A person is not disqualified from being appointed to a council vacancy merely because the person has filed nomination papers for the next municipal election. An absolute prohibition on applicants who have filed nominations would likely be characterized as an additional qualification or disqualification created by Council. Council does not have authority to add such eligibility rules.

Council may, however, require applicants to disclose whether they have filed nomination papers. Council may also consider that information as one factor in assessing the appointment, particularly in relation to public perception, neutrality, and potential advantage in the up-coming election. Therefore, which it can be considered as a factor in the decision, it should not be used as a bar to appointment.

In Conclusion

Council should not leave the vacancy unfilled as a matter of choice. Council should also refrain from imposing, as an absolute condition of eligibility for appointment, a requirement that an individual not have filed nomination papers. Persons who have filed nomination papers remain eligible if they meet the statutory qualifications. Council, however, may require disclosure of this and may consider it as part of a fair, transparent, and neutral appointment process.

BLUEWATER GEOSCIENCE

CONSULTANTS INC.

42 Shadyridge Place
Kitchener, Ontario
N2N 3J1

Tel: (519) 502-8947

E-mail: blemieux@rogers.com

May 19, 2026

Mayor White and Members of Council,
The Township of Melancthon
157101 Highway 10,
Melancthon, Ontario
L9V 2E6
Attn.: Ms. Denise Holmes, A.M.C.T., Clerk-Treasurer

Mayor White and Members of Council:

Bluewater Geoscience Consultants Inc. (Bluewater) was asked to review the report entitled “**Strada Shelburne, Annual Compliance Report**” dated March 25, 2026 and prepared by Tatham Engineering as well as comments made by Council during the May 7, 2026 Council Meeting.

The reviewed report details the 2025 groundwater and surface water monitoring and sampling activities completed for the Strada Melancthon pit. The report is completed as required by the terms of the site Permit To Take Water (PTTW) Number 3210-AKRL9C dated May 8, 2017 and the Integrated Monitoring Plan (IMP) dated February 2018.

During our review of these documents, it appears that the groundwater and surface water monitoring network stipulated in the PTTW and IMP has become degraded through time. This appears to include groundwater monitoring wells that have been destroyed/removed/blocked etc. and are no longer available for monitoring as well as surface water monitoring locations that have been removed/alterd or decommissioned and not reestablished and/or are monitored inconsistently.

Section 4.2 of the PTTW and Table 1 of the IMP provides a list of groundwater and surface water monitoring locations that are required to be monitored and/or sampled on a semi-annual or annual frequency. The requirements of the PTTW indicates these locations ‘shall’ be monitored indicating that all monitoring locations need to be maintained and should any locations become unusable, it must be replaced in a timely manner to continue compliance with the PTTW and IMP.

It appears that as many as nine of the required monitoring locations may no longer be available and/or suitable to fulfill the requirements of the PTTW and IMP. It is reasonable for Council to view these missing monitoring locations as unacceptable and they form a fundamental non-compliance with the requirements of the PTTW and IMP that requires immediate attention.

As such, Bluewater recommends that Council request from Strada (at a timing to be determined by Council) a current inventory of all surface water, pond and groundwater monitoring locations provided in Section 4.2 of the PTTW and/or Table 1 of the IMP. This inventory should include the following information for each location:

BLUEWATER GEOSCIENCE

1. Is the location currently available, suitable and included in the monitoring/sampling required in the PTTW and IMP. Also, note which stratigraphic unit each location is intended to monitor;
2. Has the location become destroyed/blocked/discontinued/removed and not reestablished, the reason for such and the year in which this occurred. This should include all monitoring locations but is particularly important for pond and surface water monitoring locations. Where any monitoring location has become unavailable or unsuitable through time, we require a 'Plan of Action' to address and reestablish each monitoring location so they can complete adequate on-going monitoring and fulfill their requirements to maintain compliance with the Terms of the PTTW and IMP;
3. Provide an inventory of any monitoring locations added on the site since the PTTW and IMP were initiated, and if they are to be added/included in the on-going monitoring and sampling moving forward. Will Strada seek to amend the PTTW and IMP to reflect/include these new monitoring locations?

During past reviews it was also noted that there have been several instances of Strada taking water outside the April 1 to November 16 time window specified in Section 3.3 of the PTTW. It is difficult to view these occurrences as accidental, as the terms of the PTTW should be quite clear to Strada, and it is reasonable for Council to view these breaches as wilful and as fundamental non-compliance with the terms of the PTTW. Council may want to request further information on why/how these breaches occurred as well as some form of commitment from Strada that it will not happen in the future.

We trust you will find this review suitable for your current requirements, however please feel free to reach out to the undersigned if you require any further information.

Sincerely,
BLUEWATER GEOSCIENCE CONSULTANTS INC.



BRETON J. LEMIEUX, M.Sc., F.G.C., QI
President, Senior Geoscientist

Date: May 19, 2026